

SL2

WITH CLAMPING HUBS

10 - 400 Nm



PROPERTIES

DESIGN

Clamping collar / clamping hub with one clamping screw each. Clutch system: spring loaded ball-detent principle. Special compact, high stiffness version. Operable temperature range from -30 to +100° C.

AVAILABLE FUNCTION SYSTEMS

- ▶ W = Single position / automatic re-engagement (standard)
- ▶ D = Multi-position / automatic re-engagement

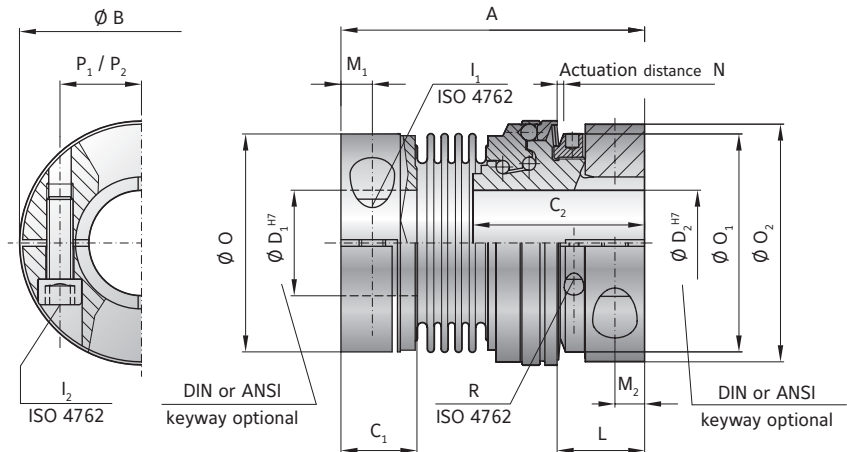

MODEL SL2

SIZE			30	60	150	300
Adjustment range* from - to	(Nm)	T _{KN}	10-35 30-80	20-50 40-100	40-100 100-200	100-250 200-350 300-400
Overall length	(mm)	A	80	93	112	126
Actuation ring diameter	(mm)	B	63	74	92	118
Hub length	(mm)	C ₁ /C ₂	21/45	23/53	28 / 63	34/72
Bore diameter from Ø to Ø H7	(mm)	D ₁ /D ₂	12-32/12-30	16-35 / 16-35	19-42 / 19-42	22-60 / 22-60
Screw ISO 4762	(mm)		M6	M8	M10	M12
Tightening torque	(Nm)	I ₁ /I ₂	15	40	75	130
Distance to actuation ring edge	(mm)	L	22	26	32	35
Distance	(mm)	M ₁ /M ₂	7.5/7.5	9.5/9	11/11	13/12
Actuation distance	(mm)	N	1.3	1.5	1.8	2
Ø Clamping hub Ø, (coupling end)	(mm)	O	55.5	66	82	110
Ø Adjustment nut	(mm)	O ₁	55	66	82	100
Clamping ring Ø, (torque limiter end)	(mm)	O ₂	59	72	90	112
Distance between centers, bellows side/safety element	(mm)	P ₁ /P ₂	20/21.5	23 / 25	27/33	39/41
Adjustment nut's clamp screw ISO 4762			M3	M3	M3	M4
Tightening torque	(Nm)	R	2	2	2	4.5
Approx. weight	(kg)		0.4	0.7	1.2	2.8
Approx. moment of inertia at D max.(10 ⁻³ Kgm ²)		J _{ges}	0.2	0.8	1.4	6.2
Torsional stiffness (10 ³ Nm/rad)			31	72	141	157
Lateral ± max. (mm)			0.2	0.2	0.2	0.25

*Maximum transmittable torque of the clamping hub depends on the bore diameter / see table on page 109.

ORDERING EXAMPLE	SL2 SK2	60	W	30	20	80	40-100	XX
Model	●							Special designation only (e.g. special bore / keyway dimensions).
Size		●						
Function system			●					
Bore D1 H7				●				
Bore D2 H7					●			
Disengagement torque Nm						●		
Torque adjustment range Nm							●	

For custom features place an XX at the end of the part number and describe the special requirements (e.g. SL2 / 60 / W / 30 / 20 / 80 / 40-100; XX=special dual keyway)

SAFETY COUPLINGS
SK | ES | SL