



# WITH KEYWAY CONNECTION

0.1 - 2,800 Nm

## PROPERTIES

### MATERIAL

► **Clutch system:** hardened steel

### DESIGN

With DIN 6885 or ANSI B17.1 keyway.  
Clutch system: spring loaded ball-detent principle. Operable temperature range from -30 to +120° C.

### AVAILABLE FUNCTION SYSTEMS

- W = Single position / automatic re-engagement (standard)
- D = Multi-position / automatic re-engagement
- G = Load holding / load blocking
- F = Full disengagement / manual re-engagement



## MINIATURE DESIGN | SIZE 1.5 - 10

Standard with keyway mounting

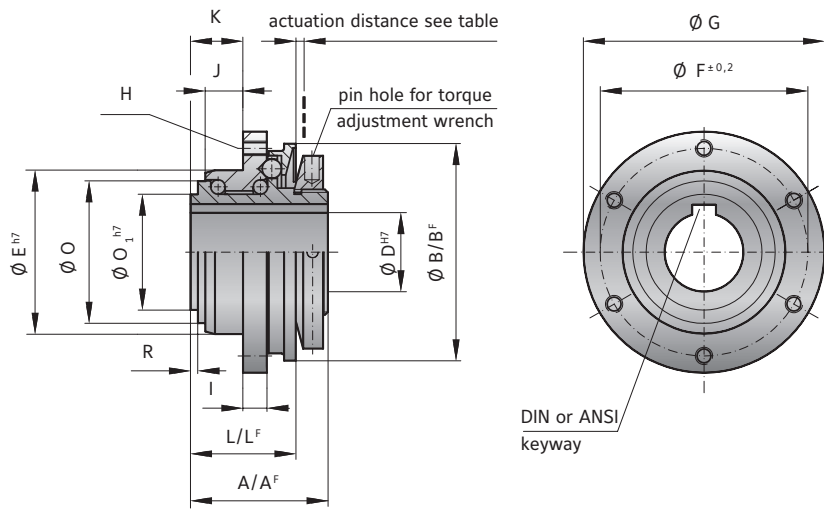

## STANDARD DESIGN | SIZE 15 - 2,500

Standard with keyway mounting

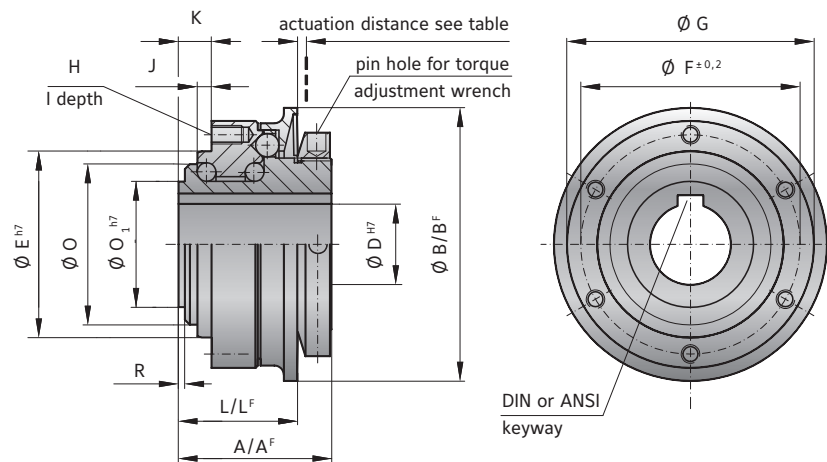

# MODEL SKP

SIZE		MINIATURE DESIGN													
		1.5	2	4.5	10	15	30	60	150	200	300	500	800	1500	2500
Adjustment range available from - to (approx. values)	(Nm) $T_{KN}$	0.1-0.6 0.4-1 0.8-2	0.2-1.5 0.5-2.2 1.5-3.5	1-3 2-4.5 3-7	2-6 4-12 7-18	5-15 12-25 20-40 35-70	5-20 10-30 20-60 50-100	10-30 25-80 50-115	20-70 45-150 80-225	30-90 60-160 140-280 250-400	100-200 150-240 220-440	80-200 200-350 320-650	400-650 500-800 650-950	600-800 700-1200 1000-1800	1500-2000 2000-2500 2300-2800
Adjustment range available from - to (approx. values) ("F" Version)	(Nm) $T_{KN}$	0.3-0.8 or 0.6-1.3	0.2-1 or 0.7-2	2.5-4.5	2-5 4-10 8-15	7-15	8-20 or 16-30	10-30 20-40 30-60	20-60 40-80 80-150	80-140 or 130-200	120-180 160-300 300-450	50-150 100-300 250-400	200-400 or 450-850	1000-1250 or 1250-1500	1400-2200 or 1800-2700
Overall length A	(mm) A	15.5	20	22	28	34	43	46	48.5	54	57	71.5	80	99	135
Overall length ("F" Version)	(mm) A <sup>F</sup>	15.5	20	22	28	34	43	46	48.5	57	60	75	91	110	141
Actuation ring Ø	(mm) B	23	29	35	45	55	65	73	92	99	120	135	152	174	242
Actuation ring Ø, ("F" Version)	(mm) B <sup>F</sup>	24	32	42	51.5	62	70	83	98	117	132	155	177	187	258
Inner diameter from Ø to Ø H7	(mm) D	4-8*	4-10*	4-12*	4-16*	8-18	12-25.4	12-28	15-38	20-42	25-50	25-58	30-60	35-73	50-98
Inner diameter with keyway DIN 6885-3 (flat)	(mm) D	-	-	-	16-18	18-20	25.4-27	28-30	38-40	42-44	50-52	58-60	60-63	73-75	98-100
Pilot diameter h7	(mm) E	14	22	25	34	40	47	55	68	75	82	90	100	125	168
Bolt-hole circle diameter ± 0.2	(mm) F	22	28	35	43	47	54	63	78	85	98	110	120	148	202
Flange outside diameter -0.2	(mm) G	26	32	40	50	53	63	72	87	98	112	128	140	165	240
Thread	H	4xM2	4xM2.5	6xM2.5	6xM3	6xM4	6xM5	6xM5	6xM6	6xM6	6xM8	6xM8	6xM10	6xM12	6xM16
Thread depth	(mm) I	3	4	4	5	6	8	9	10	10	10	12	15	16	24
Centering length -0.2	(mm) J	2.5	3.5	5	8	3	5	5	5	5	6	9	10	13.5	20
Distance	(mm) K	5	6	8	11	8	11	11	12	12	15	21	19	25	34
Distance	(mm) L	11	15	17	22	27	35	37	39	44	47	59	67	82	112
Distance, ("F" Version)	(mm) L <sup>F</sup>	11.5	16	18	24	27	37	39	41.5	47	51.5	68	75	94	120
Diameter	(mm) O	13	18	21	30	35	42	49	62	67	75	84	91	112	154
Diameter h7	(mm) O <sub>1</sub>	11	14	17	24	27	32	39	50	55	65	72	75	92	128
Distance	(mm) R	1	1.3	1.5	1.5	2.5	2.5	2.5	2.5	3	3	4	4	4.5	6
Moment of inertia (10 <sup>-3</sup> kgm <sup>2</sup> )	J <sub>ges</sub>	0.01	0.02	0.05	0.07	0.15	0.25	0.50	1.60	2.70	5.20	8.6	20	31.5	210
Approx. weight	(kg)	0.03	0.065	0.12	0.22	0.4	0.7	1.0	1.3	2.0	3.0	4.0	5.5	10	28
Actuation distance	(mm)	0.7	0.8	0.8	1.2	1.5	1.5	1.7	1.9	2.2	2.2	2.2	2.2	3.0	3.0

A<sup>F</sup>, B<sup>F</sup>, L<sup>F</sup> = Full disengagement / manual re-engagement version (F)

\* bore diameter < 6 mm delivered without keyway

## KEYWAY ACCORDING TO DIN 6885 (R+W STANDARD)

D <sub>1</sub>	from	6	8	10	12	17	22	30	38	44	50	58	65	75	85	95	110
b <sup>JS9</sup>	to	8	10	12	17	22	30	38	44	50	58	65	75	85	95	110	
h		2	3	4	5	6	8	10	12	14	16	18	20	22	25	28	
t <sub>1</sub>		2	3	4	5	6	7	8	8	9	10	11	12	14	14	16	
t <sub>2</sub>	+0.1/+0.2	1	1.4	1.8	2.3	2.8	3.3	3.3	3.3	3.8	4.3	4.4	4.9	5.4	5.4	6.4	

Bore diameters specified as common inch sizes receive standard keyways according to ANSI B17.1. Special keyway dimensions are also available upon request.

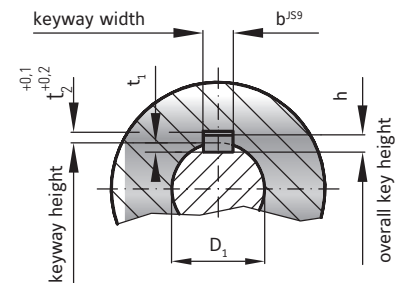

ORDERING EXAMPLE	SKP	10	W	15.88	4	2-6	XX
Model	●						Special designation only (e.g. special bore / keyway dimensions).
Size		●					
Function system			●				
Bore D1 H7				●			
Disengagement torque Nm					●		
Torque adjustment range Nm						●	
For custom features place an XX at the end of the part number and describe the special requirements (e.g. SKP / 10 / W / 15.88 / 4 / 2-6 / XX; XX=stainless steel)							