

SK3

WITH CONICAL CLAMPING SYSTEM

5 - 2,800 Nm



PROPERTIES

MATERIAL

- ▶ **Bellows:** high grade stainless steel
- ▶ **Clutch system:** hardened steel
- ▶ **Clamping hubs / bushings:** steel

Operable temperature range from -30 to +100° C.

AVAILABLE FUNCTION SYSTEMS

- ▶ **W** = Single position / automatic re-engagement (standard)
- ▶ **D** = Multi-position / automatic re-engagement
- ▶ **G** = Load holding / load blocking
- ▶ **F** = Full disengagement / manual re-engagement

DESIGN

Two conical clamping assemblies with six tightening screws each, plus jack screws for removal. Clutch system: spring loaded ball-detent principle.

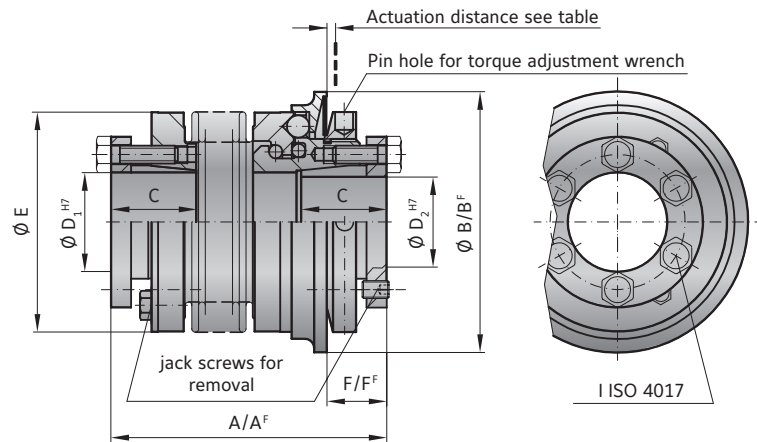

MODEL SK3

SIZE		15	30	60	150	200	300	500	800	1500	2500
Adjustment range available from (approx. values) (Nm)	T_{KN}	5-10 or 8-20	10-25 or 20-40	10-30 or 25-80	20-70 or 45-150 80-200	30-90 60-160 140-280	100-200 150-240 220-400	80-200 200-350 300-500	400-650 500-800 600-900	650-850 700-1200 1000-1800	1500-2000 2000-2500 2300-2800
Adjustment range available from (approx. values) ("F" Version) (Nm)	T_{KN}	7-15	8-20 or 16-30	20-40 or 30-60	20-60 40-80 80-150	80-140 or 130-200	120-180 or 160-300	60-150 100-300 250-500	200-400 or 450-800	1000-1250 or 1250-1500	1400-2200 or 1800-2700
Overall length ±2 (mm)	A	62 69	72 80	84 94	93 105	99 111	114 128	123 136	151	175	246
Overall length ("F" Version) ±2 (mm)	A ^F	62 69	72 80	84 94	93 105	102 114	117 131	127 140	151	184	252
Actuation ring Ø (mm)	B	55	65	73	92	99	120	135	152	174	243
Actuation ring Ø ("F" Version) (mm)	B ^F	62	70	83	98	117	132	155	177	187	258
Clamping fit length (mm)	C	19	22	27	32	32	41	41	49	61	80
Inside diameter from Ø to Ø H7 (mm)	D ₁ /D ₂	10-22	12-23	12-29	15-37	20-44	25-56	25-60	30-60	35-70	50-100
Outside diameter of coupling (mm)	E	49	55	66	81	90	110	123	133	157	200
Distance (mm)	F	13	16	18	19	19	23	25	31	30	34
Distance ("F" Version) (mm)	F ^F	13	14	17	18	17	20	22	20	26	31
6x Screw ISO 4017	I	M4	M5	M5	M6	M6	M8	M8	M10	M12	M16
Tightening torque (Nm)	I	4	6	8	12	14	18	25	40	70	120
Approx. weight (kg)		0.3	0.4	1.2	2.3	3.0	5.0	6.5	9.0	16.3	35
Moment of inertia (10 ⁻³ kgm ²)	J _{ges}	0.10 0.15	0.28 0.30	0.75 0.80	1.90 2.00	2.80 3.00	5.50 6.00	11.0 12.8	20	42	257
Torsional stiffness (10 ³ Nm/rad)	C _T	20 15	39 28	76 55	175 110	191 140	420 350	510 500	780	1304	3400
Lateral	max. values	0.15 0.20	0.20 0.25	0.20 0.25	0.20 0.25	0.25 0.30	0.25 0.30	0.30 0.35	0.35	0.35	0.35
Angular		1 1.5	1 1.5	1 1.5	1 1.5	1 1.5	2 1.5	2 2	2.5	2.5	2.5
Lateral spring stiffness		475 137	900 270	1200 380	1550 435	2040 610	3750 1050	2500 840	2000	3600	6070
Actuation distance		1.5	1.5	1.7	1.9	2.2	2.2	2.2	2.2	3	3

A^F. B^F. L^F = Full disengagement / manual re-engagement version (F) Larger versions available upon request.

ORDERING EXAMPLE	SK3 SK5	60	84	D	16	19.05	25	10-30	XX
Model	●								
Size		●							
Overall length mm			●						
Function system				●					
Bore D1 H7					●				
Bore D2 H7						●			
Disengagement torque Nm							●		
Torque adjustment range Nm								●	

For custom features place an XX at the end of the part number and describe the special requirements (e.g. SK3 / 60 / 84 / D / 16 / 19.05 / 25 / 10-30 / XX; XX=special 30 deg re-engagement angle)