



PROPERTIES

FEATURES

- ▶ for space restricted installations
- ▶ light weight and low moment of inertia
- ▶ easy to mount

MATERIAL

- ▶ **Bellows:** high grade stainless steel
- ▶ **Hubs:** see table

DESIGN

Two clamping hubs concentrically mounted to flexible bellows. Brief overloads of up to 1.5x the rated torque are acceptable.

Optional: self-opening clamp system to open the bore during installation and removal by backing out the clamping screw.

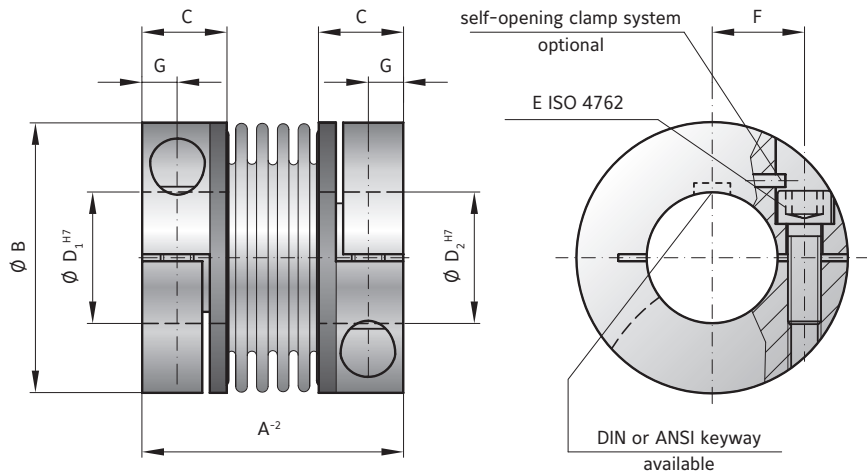

MODEL BKC

SIZE			15	30	60	150	300	500
Rated torque (Nm)	T_{KN}		15	30	60	150	300	500
Overall length (mm)	A^{-2}		48	58	67	78	94	100
Outside diameter (mm)	B		49	56	66	82	110	123
Fit length (mm)	C		16.5	21	23	27.5	34	34
Inside diameter possible from \emptyset to \emptyset H7 (mm)	D_1/D_2		8-28	12-32	14-35	19-42	24-60	32-75
Fastening screw ISO 4762	E		M5	M6	M8	M10	M12	M12
Tightening torque of the fastening screw (Nm)			8	15	40	75	120	125
Distance between centerlines (mm)	F		17.5	20	23	27	39	45
Distance (mm)	G		6.5	7.5	9.5	11	13	13
Moment of inertia (10^{-3} kgm ²)	J_{ges}		0.05	0.1	0.26	0.65	6.3	9
Hub material			AL	AL	AL	AL	steel	steel
Approximate weight (kg)			0.13	0.21	0.37	0.72	3.26	3.52
Torsional stiffness (10^3 Nm/rad)	C_T		23	31	72	141	157	290
Axial \pm (mm)	Max. values		1	1	1.5	2	2	2.5
Lateral \pm (mm)			0.2	0.2	0.2	0.2	0.2	0.2
Angular \pm (degree)			1	1	1	1	1	1
Axial spring stiffness (N/mm)	C_a		30	50	67	77	112	72
Lateral spring stiffness (N/mm)	C_r		315	366	679	960	2940	2200
Speed max. with balancing (min ⁻¹)			80,000	70,000	60,000	50,000	40,000	30,000

ORDERING EXAMPLE	BKC	60	26	22.23	XX
Model	●				Special designation only (e.g. special bore tolerance).
Size		●			
Bore D1 H7			●		
Bore D2 H7				●	

For custom features place an XX at the end of the part number and describe the special requirements (e.g. BKC / 60 / 26 / 22.23 / XX; XX=finely balanced for 25,000 rpm)