

# ST4

## WITH SIMPLE KEYWAY MOUNTING

200 - 25,000 Nm



### PROPERTIES

#### MATERIAL

- ▶ **Safety coupling portion:** hardened steel (nitrocarburized surface)
- ▶ **Gear coupling portion:** wear resistant high strength alloy steel (nitrocarburized surface)

#### DESIGN

With keyway connection (spline profile on request). Gear coupling for misalignment compensation. Safety elements evenly spaced around the circumference. Field adjustable within the specified range.

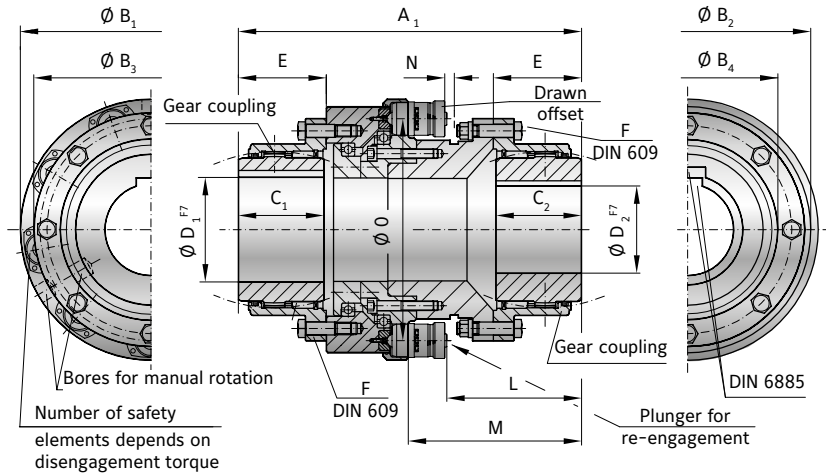

## MODEL ST4 | SIZE 2 - 25

SIZE		2			5			10			25			
Adjustment range available from - to	(kNm)		0.2-0.5	0.5-1.0	1.0-1.5	0.7-2	1.2-4	3.2-6	2-5	4-10	6-14	6-12	9-18	15-25
			3×ST10	6×ST10	6×ST10	3×ST15	6×ST15	6 ST15	3×ST15	6×ST15	9×ST15	6×ST15	9× ST15	12×ST15
Overall length	(mm)	A <sub>1</sub>	280			350			390			460		
Flange outside diameter (ST portion)	(mm)	B <sub>1</sub>	198			220			270			318		
Mounting flange outside diameter (ST portion)	(mm)	B <sub>2</sub>	192			209			259			300		
Flange outside diameter (gear coupling)	(mm)	B <sub>3</sub>	168			200			225			265		
Hub diameter (gear coupling)	(mm)	B <sub>4</sub>	130.5			158.4			183.4			211.5		
Fit length/keyway length	(mm)	C <sub>1/2</sub>	62			76			90			105		
Bore diameter Ø to Ø F7	(mm)	D <sub>1/2</sub>	30-78			32-98			42-112			46-132		
Length	(mm)	E	63.5			78.5			92.5			108		
Screw	(mm)	F	6×M8			10×M12			12×M12			12×M16		
Tightening torque	(mm)	F	18			65			65			150		
Distance	(mm)	L	110			138			159.5			202		
Distance	(mm)	M	148			188			209.5			252		
Actuation path	(mm)	N	3.5			4.5			4.5			4.5		
Mounting diameter - elements	(mm)	O	154			171			220			270		
Moment of inertia (approx.) D max. + max. sgmnt	(10 <sup>-3</sup> kgm <sup>2</sup> )		108			244			529			1117		
Speed max.	(rpm)		4000			3900			3700			3550		
Approx. weight at D max. + max. sgmnt	(kg)		25			45			65			100		
Axial	(mm)		1.5			2.5			2.5			3		
Angular	(Degrees)		2×0.35°			2×0.35°			2×0.35°			2×0.35°		

\* Larger bore diameters upon request. | For technical information about the gear coupling segments see page 19.

# ST4

## WITH SIMPLE KEYWAY MOUNTING

12,000 - 250,000 Nm



### PROPERTIES

#### MATERIAL

- ▶ **Safety coupling portion:** hardened steel (nitrocarburized surface)
- ▶ **Gear coupling portion:** wear resistant high strength alloy steel (nitrocarburized surface)

#### DESIGN

With keyway connection (spline profile on request). Gear coupling for misalignment compensation. Safety elements evenly spaced around the circumference. Field adjustable within the specified range.

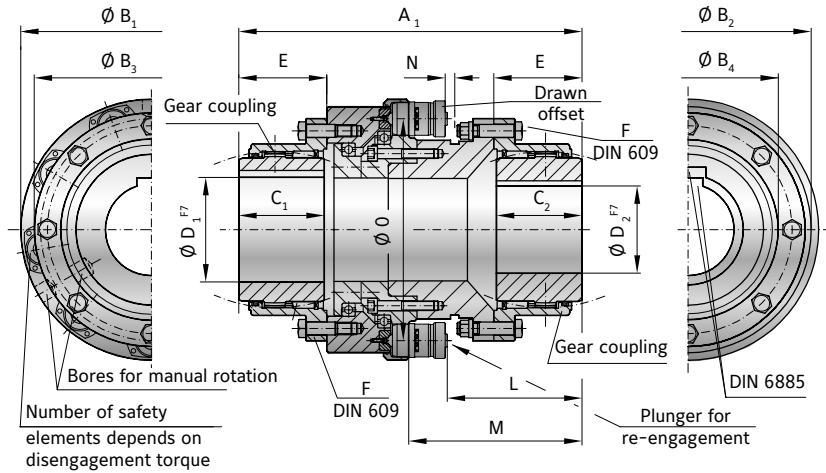

## MODEL ST4 | SIZE 40 - 250

SIZE		40			60			100			160			250	
Adjustment range available from - to	(kNm)	12-21	22-32	32-45	11-18	22-36	30-55	24-50	45-90	80-110	25-55	50-110	80-165	100-170	160-250
		6×ST30	6×ST30	9×ST30	3×ST30	6×ST30	9×ST30	3×ST70	6×ST70	9×ST70	3×ST70	6×ST70	9×ST70	8×ST71	12×ST71
Overall length	(mm)	A <sub>1</sub>	580			650			780			860		1060	
Flange outside diameter (ST portion)	(mm)	B <sub>1</sub>	428			459			592			648		740	
Mounting flange outside diameter (ST portion)	(mm)	B <sub>2</sub>	399			418			560			618		724	
Flange outside diameter (gear coupling)	(mm)	B <sub>3</sub>	330			370			438			525		639	
Hub diameter (gear coupling)	(mm)	B <sub>4</sub>	275.5			307			367			423		553	
Fit length/keyway length	(mm)	C <sub>1/2</sub>	135			150			190			220		290	
Bore diameter Ø to Ø F7	(mm)	D <sub>1/2</sub>	60-174			70-190			110-233			120-280		200-340	
Length	(mm)	E	139			154			194			225		296	
Screw	(mm)	F	14×M16			14×M18			14×M22			16×M24		22×M24	
Tightening torque	(mm)	F	150			220			400			520		670	
Distance	(mm)	L	238			275			318			360		458	
Distance	(mm)	M	306			343			408			450		534	
Actuation path	(mm)	N	8			8			10			10		10	
Mounting diameter - elements	(mm)	O	350			376			490			532		630	
Moment of inertia (approx.) D max. + max. sgmnt	(10 <sup>-3</sup> kgm <sup>2</sup> )		4363			6650			20611			33820		84926	
Speed max.	(rpm)		2750			2420			1950			1730		950	
Approx. weight at D max. + max. sgmnt	(kg)		225			293			570			718		1280	
Axial	(mm)		4			4			4			5		6	
Angular	(Degrees)		2×0.35°			2×0.35°			2×0.35°			2×0.35°		2×0.35°	

\* larger bore diameters upon request. | For technical information about the gear coupling segments see page 19.