

ST2

WITH SIMPLE KEYWAY MOUNTING

200 - 25,000 Nm



NEW: ATEX

PROPERTIES

MATERIAL

- ▶ **Safety coupling portion:** hardened steel (nitrocarburized surface)
- ▶ **Elastomer segments:** precision molded, wear resistant rubber compound (75-80 Shore A)
- ▶ **Elastomer coupling:** hubs made from coated high strength cast steel

DESIGN

With keyway connection (spline profile on request). Elastomer segments compensate for misalignment and absorb vibration. Safety elements evenly spaced around the circumference. Field adjustable within the specified range.

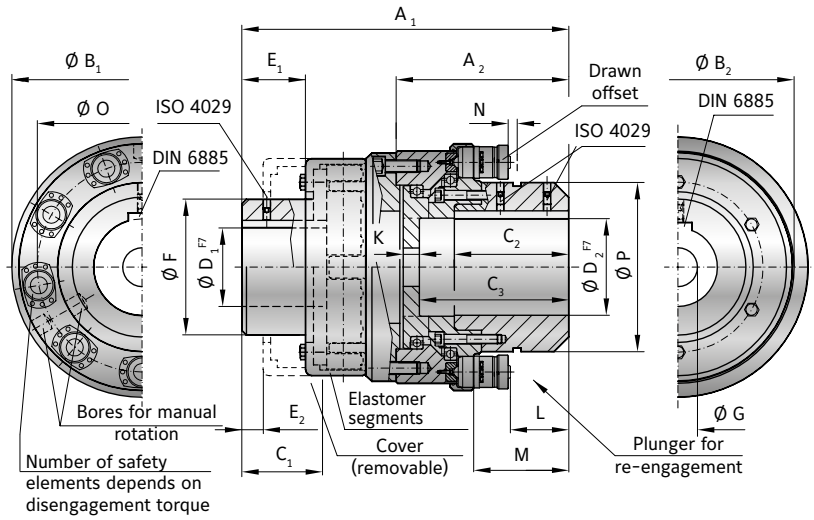

MODEL ST2 | SIZE 2 - 25

SIZE		2			5			10			25		
Adjustment range available from - to (KNm)		0.2-0.5	0.5-1.0	1.0-1.5	0.7-2	1.2-4	3.2-5	2-5	4-10	6-14	6-12	9-18	15-25
		3×ST10	6×ST10	6×ST10	3×ST15	6×ST15	6×ST15	3×ST15	6×ST15	9×ST15	6×ST15	9×ST15	12×ST15
Overall length ±2 (mm)	A ₁	264			313			360			437		
Length of torque limiting portion (mm)	A ₂	120			150			183			230		
Flange outside diameter (ST portion) (mm)	B ₁	198			220			270			318		
Flange outside diameter (elastomer portion) (mm)	B ₂	221			250			290			330		
Fit length/keyway length D1 (mm)	C ₁	82			89			97			116		
Fit length/keyway length D2 (mm)	C ₂	100			121			120			155		
Bore depth (torque limiting portion) (mm)	C ₃	100			124			158			200		
Bore diameter (elastomer portion) Ø - Ø F7 (mm)	D ₁	30-80			40-100			40-105			60-130		
Bore diameter (torque limiting portion) Ø - Ø F7 (mm)	D ₂	30-75			40-90			40-110			60-140		
Length to cover (mm)	E ₁	65			70			70			87		
Length to (cover removed) (mm)	E ₂	24			23			22			26		
Hub diameter (mm)	F	130			145			160			200		
Bore for fastening screw (mm)	G	max. Ø 75			max. Ø 90			max. Ø 110			max. Ø 140		
Distance (mm)	L	10.5			16.5			45			80		
Distance (mm)	M	51.5			66.5			95			130		
Actuation path (mm)	N	3.5			4.0			4			4		
Mounting diameter - elements (mm)	O	154			171			220			270		
Hub outside diameter (mm)	P	104			120			170			218		
Moment of inertia (approx.) D max. + max. sgmnt (10 ⁻³ kgm ²)		152			289			854			1850		
Speed max. (rpm)		3400			3000			2400			2000		
Approx. weight at D max. + max. sgmnt (kg)		29			43.7			93			115		
Axial (mm)		1.5			1.5			1.5			1.5		
Lateral (mm)		0.3			0.4			0.4			0.5		
Angular (degree)		1			1			1			1		
Dynamic torsional stiffness at T _{KN} (Standard A Insert) (10 ³ Nm/rad)		58			92			145			230		

* larger bore diameters upon request. | For technical information about the elastomer insert segments see guide book page 29.

ST2

WITH SIMPLE KEYWAY MOUNTING

12,000 - 165,000 Nm



NEW: ATEX

PROPERTIES

MATERIAL

- ▶ **Safety coupling portion:** hardened steel (nitrocarburized surface)
- ▶ **Elastomer segments:** precision molded, wear resistant rubber compound (75-80 Shore A)
- ▶ **Elastomer coupling:** hubs made from coated high strength cast steel

DESIGN

With keyway connection (spline profile on request). Elastomer segments compensate for misalignment and absorb vibration. Safety elements evenly spaced around the circumference. Field adjustable within the specified range.

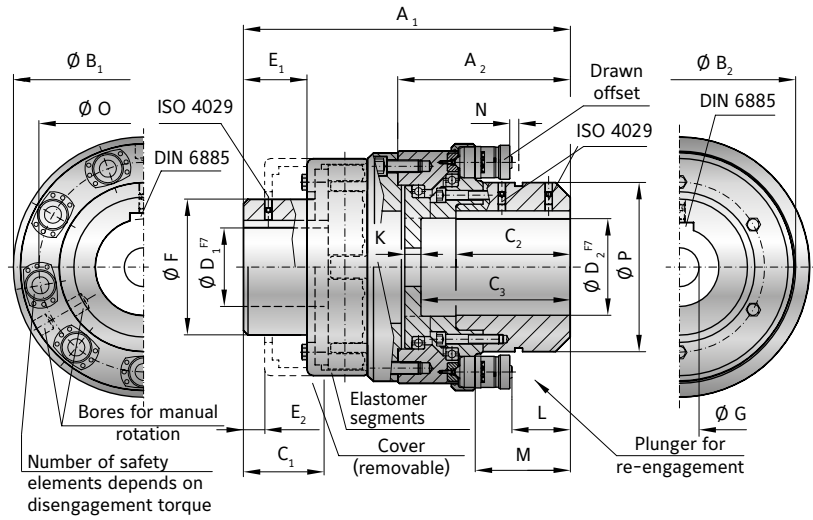

MODEL ST2 | SIZE 40 - 160

SIZE		40			60			100			160		
Adjustment range available from - to (KNm)		12-21	22-32	32-45	11-18	22-36	30-55	24-50	45-90	80-110	25-55	50-110	80-165
		6×ST30	6×ST30	9×ST30	3×ST 30	6×ST 30	9×ST 30	3×ST70	6×ST70	9×ST70	3×ST70	6×ST70	9×ST70
Overall length ±2 (mm)	A ₁	565			580			716			730		
Length of torque limiting portion (mm)	A ₂	305			320			396			410		
Flange outside diameter (ST portion) (mm)	B ₁	428			459			592			648		
Flange outside diameter (elastomer portion) (mm)	B ₂	432			432			553			553		
Fit length/keyway length D1 (mm)	C ₁	160			160			230			230		
Fit length/keyway length D2 (mm)	C ₂	170			220			280			290		
Bore depth (torque limiting portion) (mm)	C ₃	210			275			280			360		
Bore diameter (elastomer portion) Ø - Ø F7 (mm)	D ₁	90-170			80-160			100-200			100-200		
Bore diameter (torque limiting portion) Ø - Ø F7 (mm)	D ₂	90-170			80-200			100-250			100-290		
Length to cover (mm)	E ₁	113			112			152			152		
Length to (cover removed) (mm)	E ₂	39			39			65			65		
Hub diameter (mm)	F	255			255			300			300		
Bore for fastening screw (mm)	G	max. Ø 144			max. Ø 200			max. Ø 216			max. Ø 290		
Distance (mm)	L	102			99			128			135		
Distance (mm)	M	170			167			218			225		
Actuation path (mm)	N	7.5			7.5			10			10		
Mounting diameter - elements (mm)	O	350			376			490			532		
Hub outside diameter (mm)	P	265			295			380			418		
Moment of inertia (approx.) D max. + max. sgmnt (10 ⁻³ kgm ²)		6010			8960			21890			36858		
Speed max. (rpm)		1800			1800			1500			1500		
Approx. weight at D max. + max. sgmnt (kg)		271			287			642			729		
Axial (mm)		2			2			2.5			2.5		
Lateral (mm)		0.6			0.6			0.7			0.7		
Angular (degree)		1			1			1			1		
Dynamic torsional stiffness at T _{KN} (Standard A Insert) (10 ³ Nm/rad)		500			580			850			1000		

* larger bore diameters upon request. | For technical information about the elastomer insert segments see guide book page 29.