

ST1

WITH SIMPLE KEYWAY MOUNTING

200 - 45,000 Nm

PROPERTIES

MATERIAL

Hardened steel (nitrocarburized surface)

► Driven side: output flange with 12x fastening threads and integral bearings

DESIGN

► Drive side: coupling hub with keyway connection (spline profile on request)

► Safety elements: evenly spaced around the circumference; externally adjustable

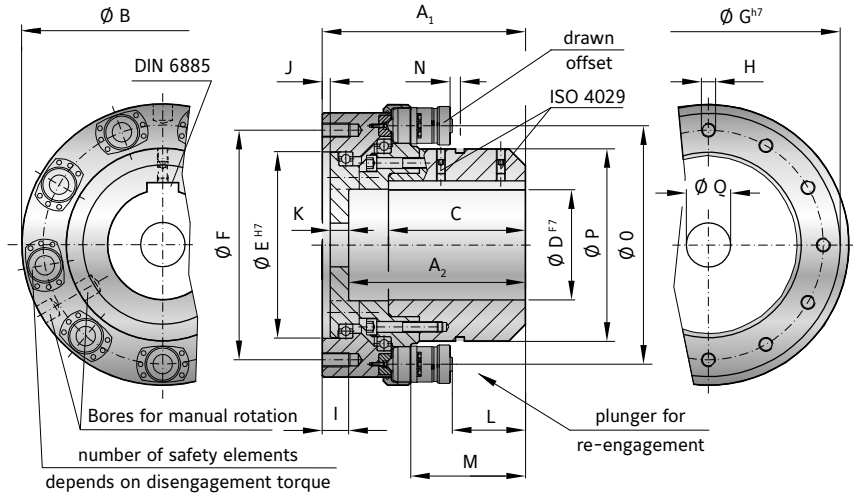

MODEL ST1 | SIZE 2 - 40

SIZE		2			5			10			25			40		
Adjustment range available from - to (KNm)		0.2-0.5	0.5-1.0	1.0-1.5	0.7-2	1.2-4	3.2-5	2-5	4-10	6-14	6-12	9-18	15-25	12-21	22-32	32-45
		3×ST10	6×ST10	6×ST10	3×ST15	6×ST15	6×ST15	3×ST15	6×ST15	9×ST15	6×ST15	9×ST15	12×ST15	6×ST30	6×ST30	9×ST30
Overall length (mm)	A ₁	120			150			183			230			305		
Bore depth (mm)	A ₂	100			124			158			200			210		
Outside diameter (mm)	B	198			220			270			318			428		
Fit length (mm)	C	100			121			120			155			210		
Bore diameter possible Ø to Ø F7 (mm)	D	30-75			40-90			40-110			60-140			90-170		
Flange centering diameter H7 (mm)	E	132			145			170			210			270		
Bolt circle diameter ±0.3 (mm)	F	162			170			220			260			330		
Flange outside diameter h7 (mm)	G	192			209			259			298			380		
Fastening threads	H	12xM10			12xM12			12xM16			12xM16			12xM20		
Thread depth (mm)	I	15			20			25			30			35		
Fit length (mm)	J	3.5			4			6			8			8		
Wall thickness (mm)	K	15			21			17			20			28		
Distance (mm)	L	10.5			16.5			45			80			102		
Distance (mm)	M	51.5			66.5			95			130			170		
Actuation path (mm)	N	3.5			4.5			4			4			7.5		
Mounting diameter - elements (mm)	O	154			171			220			270			350		
Hub outside diameter (mm)	P	104			120			170			218			265		
Bore for fastening screw (mm)	Q	max. Ø 75			max. Ø 90			max. Ø 110			max. Ø 140			max. Ø 144		
Moment of inertia (approx.) D max. + max. sgmnt (10 ⁻³ kgm ²)		77			151			370			780			3570		
Speed max. (rpm)		7000			6000			4200			3800			3000		
Allowable max. radial force standard* (kN)		5			10			20			30			40		
Approx. weight at D max. + max. sgmnt (kg)		15			24			40			63			166		

* larger radial loads possible with special bearings

ST1

WITH SIMPLE KEYWAY MOUNTING

11,000 - 250,000 Nm

PROPERTIES

MATERIAL

Hardened steel (nitrocarburized surface)

- ▶ Driven side: output flange with 12x fastening threads and integral bearings

DESIGN

- ▶ Drive side: coupling hub with keyway connection (spline profile on request)
- ▶ Safety elements: evenly spaced around the circumference; externally adjustable

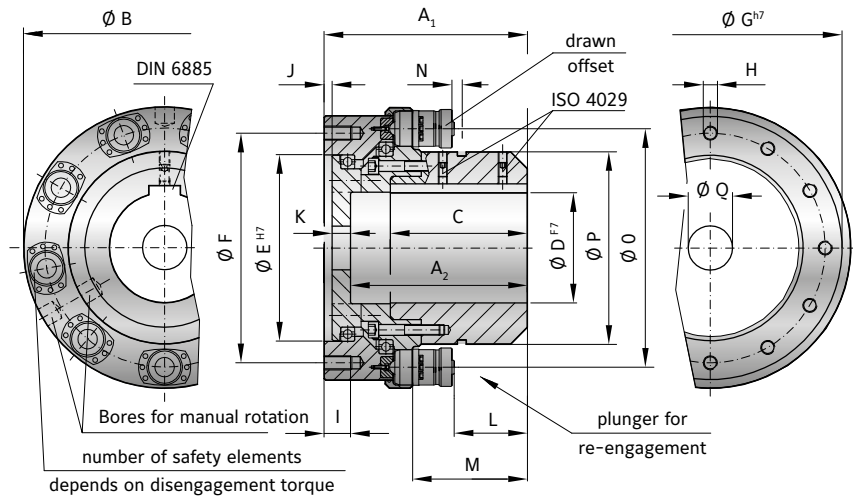

MODEL ST1 | SIZE 60 - 250

SIZE		60			100			160			250	
Adjustment range available from - to (KNm)		11-18	22-36	30-55	24-50	45-90	80-110	25-55	50-110	80-165	100-170	160-250
		3xST 30	6xST 30	9xST 30	3xST70	6xST70	9xST70	3xST70	6xST70	9xST70	8xST71	12xST71
Overall length (mm)	A ₁	320			396			410			534	
Bore depth (mm)	A ₂	275			280			360			370	
Outside diameter	B	459			592			648			740	
Fit length (mm)	C	220			280			290			370	
Bore diameter possible Ø to Ø F7 (mm)	D	80-200			100-250			100-290			200-340	
Flange centering diameter H7 (mm)	E	300			390			450			508	
Bolt circle diameter ±0.3 (mm)	F	360			464			570			600	
Flange outside diameter h7 (mm)	G	418			530			618			680	
Fastening threads	H	12xM20			12xM24			12xM24			12xM36	
Thread depth (mm)	I	35			40			40			60	
Fit length (mm)	J	8			10			10			12	
Wall thickness (mm)	K	30			38			38			60	
Distance (mm)	L	99			128			135			135	
Distance (mm)	M	167			218			225			228	
Actuation path (mm)	N	7,5			10			10			10	
Mounting diameter - elements (mm)	O	376			490			532			630	
Hub outside diameter (mm)	P	295			380			418			508	
Bore for fastening screw (mm)	Q	max. Ø 200			max. Ø 216			max. Ø 290			max. Ø 290	
Moment of inertia (approx.) D max. + max. sgmnt (10 ⁻³ kgm ²)		4600			16850			24600			56800	
Speed max. (rpm)		2500			2200			2000			1200	
Allowable max. radial force standard* (KN)		50			60			100			120	
Approx. weight at D max. + max. sgmnt (kg)		179			403			463			850	

* larger radial loads possible with special bearings