



# WPSFN

## The shortest spiral right angle gearbox with flange output shaft and hollow shaft

Our **WPSFN** is extremely light and easy to integrate thanks to its standardized flange interface. It achieves optimized synchronization with the spiral gearing and the helical-toothed planetary stage for the best surface qualities. The shortest right angle precision gearbox with integrated hollow shaft provides you with new structural solutions.

Nominal output torque **22 - 625 Nm**



Radial force **2150 - 12000 N**



Axial force **4200 - 9500 N**



Torsional backlash **3 - 5 arcmin**



Protection class **IP65**



Frame sizes

- 64
- 90
- 110
- 140

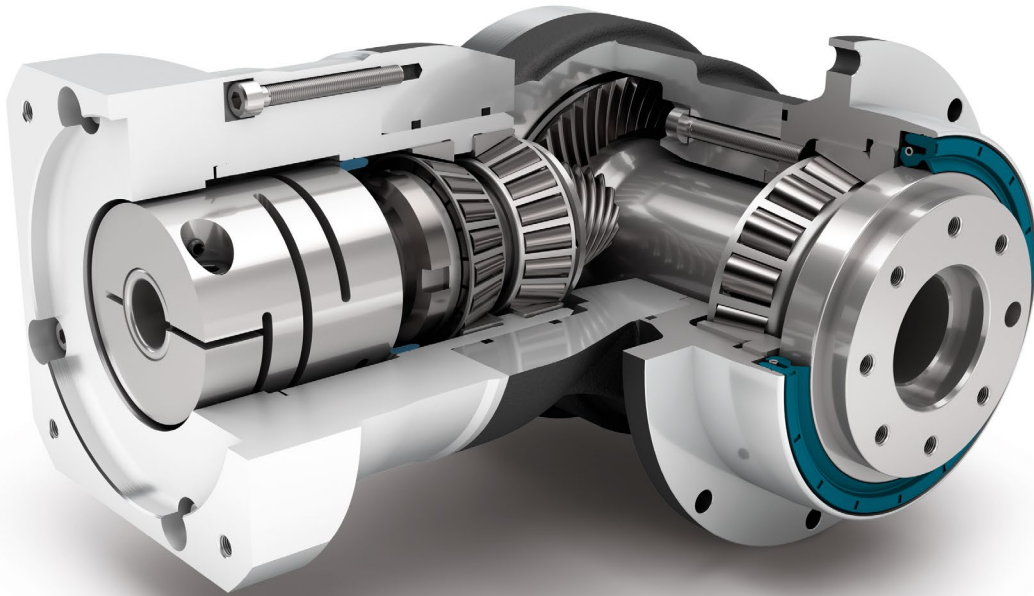

Precision Line



Right angle gearbox



Hypoid gear right angle stage



Preloaded angular contact roller bearings



Flange output shaft (ISO 9409)



Option: Reduced backlash (2-stage)



Counterdirectional rotation

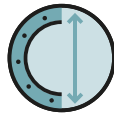

Extra large round type output flange



Rotary shaft seal



Hollow shaft (1-stage)



Option: Planetary gearbox with mounted pinion on page 140

Detailed explanations of the technical features starting on page 169.

Code	Gearbox characteristics			WPSFN064	WPSFN090	WPSFN110	WPSFN140	p <sup>(1)</sup>	
	Service life (L <sub>10h</sub> )	t <sub>L</sub>	h	20,000					
	Service life at T <sub>2N</sub> x 0,88			30,000					
	Efficiency at full load <sup>(2)</sup>	η	%	94				1	
				93				2	
	Min. operating temperature	T <sub>min</sub>	°C (°F)	-25 (-13)					
	Max. operating temperature	T <sub>max</sub>		90 (194)					
	Protection class	IP65							
<b>S</b>	Standard lubrication	Oil (lifetime lubrication)							
<b>F</b>	Food grade lubrication	Oil (lifetime lubrication)							
	Installation position	Any							
<b>S</b>	Standard backlash	< 5							
<b>R</b>	Reduced backlash	j <sub>t</sub>	arcmin	-				1	
				< 3				2	
	Torsional stiffness <sup>(2)</sup>	c <sub>g</sub>	Nm /arcmin (lb <sub>f</sub> .in/ arcmin)	1.9 - 2.6 (17 - 23)	4.0 - 5.5 (35 - 49)	10.1 - 13.5 (89 - 119)	26.0 - 34.5 (230 - 305)	1	
				5.3 - 6.9 (47 - 61)	15.3 - 20.5 (135 - 181)	33.5 - 44.0 (296 - 389)	85.0 - 111.0 (752 - 982)	2	
	Gearbox weight <sup>(2)</sup>	m <sub>G</sub>	kg (lb <sub>m</sub> )	3.5 - 3.6 (7.7 - 7.8)	6.6 - 7.0 (14.5 - 15.5)	11.6 - 11.7 (25.6 - 25.8)	25.4 - 26.0 (56.1 - 57.3)	1	
				3.9 - 4.0 (8.7 - 8.9)	5.6 - 5.7 (12.3 - 12.6)	9.0 - 9.3 (19.8 - 20.5)	19.2 - 19.7 (42.3 - 43.4)	2	
<b>S</b>	Standard surface	Right angle housing: Aluminum – anodized (black)							
	Running noise <sup>(3)</sup>	Q <sub>g</sub>	dB(A)	66	67	68	70		
	Max. bending moment based on the gearbox input flange <sup>(4)</sup>	M <sub>b</sub>	Nm (lb <sub>f</sub> .in)	12 (106)	25.5 (226)	53 (469)	120 (1062)	1	
				12 (106)	12 (106)	25.5 (226)	53 (469)	2	

Output shaft loads				WPSFN064	WPSFN090	WPSFN110	WPSFN140	p <sup>(1)</sup>
Radial force for 20,000 h <sup>(5)(6)</sup>	F <sub>r20.000h</sub>			2400 (540)	4400 (989)	5500 (1236)	12000 (2698)	1
				2150 (483)	3950 (888)	4900 (1102)	12000 (2698)	2
Axial force for 20,000 h <sup>(5)(6)</sup>	F <sub>a20.000h</sub>			4200 (944)	7200 (1619)	9500 (2136)	8500 (1911)	1
				4300 (967)	8200 (1843)	9500 (2136)	8500 (1911)	2
Radial force for 30,000 h <sup>(5)(6)</sup>	F <sub>r30.000h</sub>		N (lb <sub>f</sub> )	2100 (472)	3900 (877)	4800 (1079)	11000 (2473)	1
				1900 (427)	3500 (787)	4350 (978)	11000 (2473)	2
Axial force for 30,000 h <sup>(5)(6)</sup>	F <sub>a30.000h</sub>			3700 (832)	6300 (1416)	8400 (1888)	7500 (1686)	1
				3800 (854)	7200 (1619)	8400 (1888)	7500 (1686)	2
Maximum radial force <sup>(7)(6)</sup>	F <sub>rStat</sub>			2400 (540)	4400 (989)	5500 (1236)	12000 (2698)	1
				2150 (483)	3950 (888)	4900 (1102)	12000 (2698)	2
Maximum axial force <sup>(7)(6)</sup>	F <sub>aStat</sub>			4200 (944)	7200 (1619)	9500 (2136)	8500 (1911)	1
				4300 (967)	8200 (1843)	9500 (2136)	8500 (1911)	2
Tilting moment for 20,000 h <sup>(5)(7)</sup>	M <sub>K20.000h</sub>		Nm (lb <sub>f</sub> .in)	200 (1770)	484 (4284)	689 (6098)	1989 (17604)	1
				132 (1168)	326 (2885)	475 (4204)	1030 (9116)	2
Tilting moment for 30,000 h <sup>(5)(7)</sup>	M <sub>K30.000h</sub>			175 (1549)	429 (3797)	601 (5319)	1823 (16135)	1
				117 (1036)	289 (2558)	422 (3735)	944 (8355)	2

Moment of inertia				WPSFN064	WPSFN090	WPSFN110	WPSFN140	p <sup>(1)</sup>
Mass moment of inertia <sup>(2)</sup>	J	kgcm <sup>2</sup> (lb <sub>f</sub> .in.s <sup>2</sup> 10 <sup>-4</sup> )		0.502 - 0.672 (4.443 - 5.948)	1.046 - 1.591 (9.258 - 14.082)	4.857 - 6.435 (42.988 - 56.955)	15.220 - 21.693 (134.708 - 191.999)	1
				0.497 - 0.642 (4.399 - 5.682)	0.497 - 0.659 (4.399 - 5.833)	1.015 - 1.452 (8.984 - 12.851)	4.810 - 6.449 (42.572 - 57.078)	2

(1) Number of stages  
(2) The ratio-dependent values can be retrieved in Tec Data Finder – www.neugart.com  
(3) Sound pressure level from 1 m, measured on input running at n<sub>1</sub>=3000 rpm no load; i=5  
(4) Max. motor weight\* in kg = 0.2 x M<sub>g</sub> / motor length in m  
\* with symmetrically distributed motor weight  
\* with horizontal and stationary mounting  
(5) These values are based on an output shaft speed of n<sub>2</sub>=100 rpm  
(6) Based on the end of the output shaft  
(7) Other (sometimes higher) values following changes to T<sub>2N</sub>, F<sub>r</sub>, F<sub>a</sub>, cycle, and service life of bearing. Application specific configuration with NCP – www.neugart.com

Output torques			WPSFN064	WPSFN090	WPSFN110	WPSFN140	i <sup>(1)</sup>	p <sup>(2)</sup>
Nominal output torque <sup>(3)</sup>	T <sub>2N</sub>	Nm (lb <sub>r</sub> .in)	45 (398)	90 (797)	160 (1416)	320 (2832)	4	1
			42 (372)	75 (664)	140 (1239)	280 (2478)	5	
			28 (248)	51 (451)	91 (805)	189 (1673)	7	
			27 (239)	50 (443)	90 (797)	180 (1593)	8	
			22 (195)	40 (354)	75 (664)	160 (1416)	10	2
			62 (549)	130 (1151)	310 (2744)	625 (5532)	16	
			62 (549)	130 (1151)	300 (2655)	560 (4956)	20	
			60 (531)	120 (1062)	255 (2257)	540 (4779)	25	
			62 (549)	112 (991)	204 (1806)	364 (3222)	28	
			62 (549)	108 (956)	200 (1770)	360 (3186)	32	
			60 (531)	123 (1089)	255 (2257)	455 (4027)	35	
			60 (531)	123 (1089)	250 (2213)	450 (3983)	40	
			60 (531)	110 (974)	200 (1770)	375 (3319)	50	
			37 (327)	78 (690)	175 (1549)	355 (3142)	70	
28 (248)	59 (522)	140 (1239)	305 (2699)	100				
Max. output torque <sup>(4)</sup>	T <sub>2max</sub>	Nm (lb <sub>r</sub> .in)	72 (637)	144 (1275)	256 (2266)	512 (4532)	4	1
			67 (593)	120 (1062)	224 (1983)	448 (3965)	5	
			45 (398)	82 (726)	145 (1283)	302 (2673)	7	
			43 (381)	80 (708)	144 (1275)	288 (2549)	8	
			35 (310)	64 (566)	120 (1062)	256 (2266)	10	2
			99 (876)	210 (1859)	502 (4443)	1003 (8877)	16	
			99 (876)	210 (1859)	480 (4248)	896 (7930)	20	
			96 (850)	197 (1744)	408 (3611)	864 (7647)	25	
			99 (876)	180 (1593)	328 (2903)	580 (5133)	28	
			99 (876)	172 (1522)	320 (2832)	576 (5098)	32	
			96 (850)	197 (1744)	410 (3629)	725 (6417)	35	
			96 (850)	197 (1744)	400 (3540)	720 (6373)	40	
			96 (850)	175 (1549)	320 (2832)	600 (5310)	50	
			59 (522)	125 (1106)	280 (2478)	568 (5027)	70	
45 (398)	94 (832)	224 (1983)	488 (4319)	100				

<sup>(1)</sup> Ratios (i=n<sub>1</sub>/n<sub>2</sub>)  
<sup>(2)</sup> Number of stages  
<sup>(3)</sup> Application specific configuration with NCP – www.neugart.com  
<sup>(4)</sup> 30,000 rotations of the output shaft permitted; see page 158

Output torques			WPSFN064	WPSFN090	WPSFN110	WPSFN140	i <sup>(1)</sup>	p <sup>(2)</sup>
Emergency stop torque <sup>(3)</sup>	T <sub>2Stop</sub>	Nm (lb <sub>f</sub> .in)	100 (885)	200 (1770)	400 (3540)	800 (7081)	4	1
			100 (885)	200 (1770)	400 (3540)	800 (7081)	5	
			75 (664)	150 (1328)	300 (2655)	700 (6196)	7	
			75 (664)	150 (1328)	300 (2655)	700 (6196)	8	
			75 (664)	150 (1328)	300 (2655)	700 (6196)	10	
		150 (1328)	300 (2655)	650 (5753)	1600 (14161)	16	2	
		150 (1328)	300 (2655)	650 (5753)	1600 (14161)	20		
		150 (1328)	300 (2655)	650 (5753)	1650 (14604)	25		
		150 (1328)	300 (2655)	600 (5310)	1200 (10621)	28		
		150 (1328)	300 (2655)	600 (5310)	1200 (10621)	32		
		150 (1328)	300 (2655)	650 (5753)	1500 (13276)	35		
		150 (1328)	300 (2655)	650 (5753)	1500 (13276)	40		
		150 (1328)	300 (2655)	650 (5753)	1500 (13276)	50		
		80 (708)	175 (1549)	340 (3009)	1300 (11506)	70		
		90 (797)	200 (1770)	480 (4248)	600 (5310)	100		

Input speeds			WPSFN064	WPSFN090	WPSFN110	WPSFN140	i <sup>(1)</sup>	p <sup>(2)</sup>
Average thermal input speed at T <sub>2N</sub> and S1 <sup>(4)(5)</sup>	n <sub>1N</sub>	rpm	1850 <sup>(6)</sup>	1650 <sup>(6)</sup>	1100 <sup>(6)</sup>	1000 <sup>(6)</sup>	4	1
			2050 <sup>(6)</sup>	1900 <sup>(6)</sup>	1200 <sup>(6)</sup>	1100 <sup>(6)</sup>	5	
			2450 <sup>(6)</sup>	2350 <sup>(6)</sup>	1450 <sup>(6)</sup>	1300 <sup>(6)</sup>	7	
			2500 <sup>(6)</sup>	2400 <sup>(6)</sup>	1450 <sup>(6)</sup>	1300 <sup>(6)</sup>	8	
			2650 <sup>(6)</sup>	2550 <sup>(6)</sup>	1500 <sup>(6)</sup>	1400 <sup>(6)</sup>	10	
		2250 <sup>(6)</sup>	2100 <sup>(6)</sup>	1750 <sup>(6)</sup>	1400 <sup>(6)</sup>	16	2	
		2400 <sup>(6)</sup>	2300 <sup>(6)</sup>	2000 <sup>(6)</sup>	1350 <sup>(6)</sup>	20		
		2500 <sup>(6)</sup>	2600 <sup>(6)</sup>	2300 <sup>(6)</sup>	1450 <sup>(6)</sup>	25		
		2550 <sup>(6)</sup>	2650 <sup>(6)</sup>	2400 <sup>(6)</sup>	1650 <sup>(6)</sup>	28		
		2550 <sup>(6)</sup>	2700 <sup>(6)</sup>	2450 <sup>(6)</sup>	1650 <sup>(6)</sup>	32		
		2750 <sup>(6)</sup>	2850 <sup>(6)</sup>	2450 <sup>(6)</sup>	1650 <sup>(6)</sup>	35		
		2800 <sup>(6)</sup>	2750 <sup>(6)</sup>	2500 <sup>(6)</sup>	1650 <sup>(6)</sup>	40		
		2750 <sup>(6)</sup>	2900 <sup>(6)</sup>	2650 <sup>(6)</sup>	1750 <sup>(6)</sup>	50		
		3000 <sup>(6)</sup>	3300 <sup>(6)</sup>	3000 <sup>(6)</sup>	1950 <sup>(6)</sup>	70		
		3050 <sup>(6)</sup>	3600 <sup>(6)</sup>	3300 <sup>(6)</sup>	2150 <sup>(6)</sup>	100		
Max. mechanical input speed <sup>(4)</sup>	n <sub>1Limit</sub>	rpm	16000	14000	9500	8000		1
			16000	16000	14000	9500		2

(1) Ratios (i=n<sub>1</sub>/n<sub>2</sub>)  
 (2) Number of stages  
 (3) Permitted 1000 times  
 (4) Application-specific speed configurations with NCP – www.neugart.com  
 (5) See page 158 for the definition  
 (6) Average thermal input speed at 50% T<sub>2N</sub> and S1

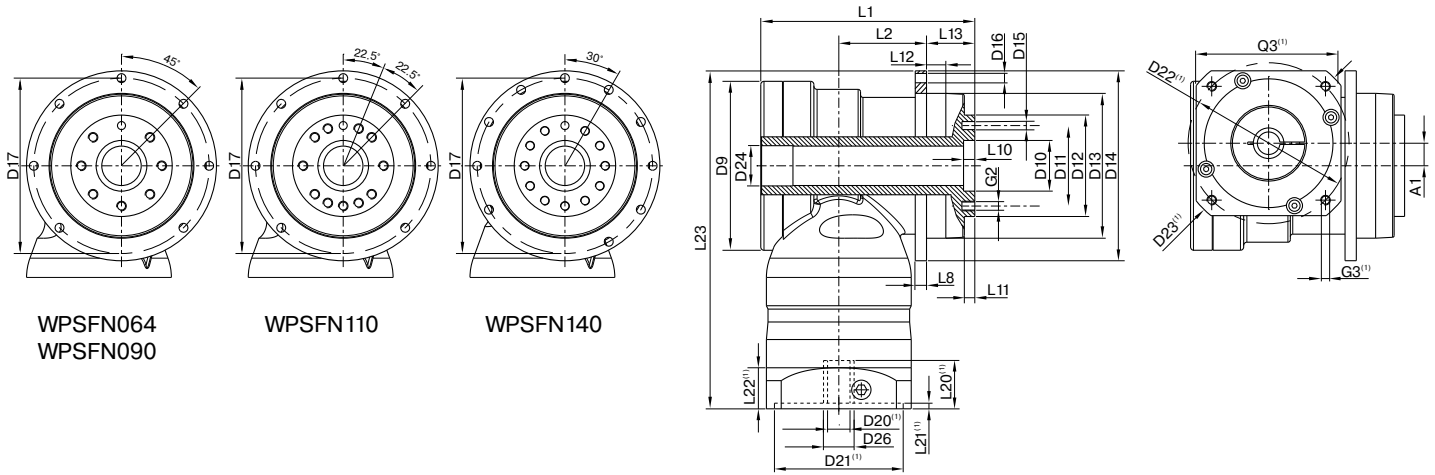

WPSFN064  
WPSFN090

WPSFN110

WPSFN140

Drawing corresponds to a WPSFN090 / 1-stage / flange hollow output shaft / 19 mm clamping system / motor adaptation – 2-part – round universal flange / B5 flange type motor

<sup>(1)</sup> The dimensions vary with the motor/gearbox flange. The input flange dimensions can be retrieved for each specific motor in Tec Data Finder at [www.neugart.com](http://www.neugart.com)

Geometry <sup>(2)</sup>			WPSFN064	WPSFN090	WPSFN110	WPSFN140	p <sup>(3)</sup>	Code
Axis offset	A1		10 (0.394)	14 (0.551)	20 (0.787)	26 (1.024)	1	
			10 (0.394)	10 (0.394)	14 (0.551)	20 (0.787)	2	
Max. diameter	D9		86 (3.386)	105 (4.134)	120 (4.724)	170 (6.693)	1	
			86 (3.386)	86 (3.386)	105 (4.134)	120 (4.724)	2	
Centering diameter output shaft	D10	H7	20 (0.787)	31.5 (1.240)	40 (1.575)	50 (1.969)		
Pitch circle diameter output shaft	D11		31.5 (1.240)	50 (1.969)	63 (2.480)	80 (3.150)		
Flange output shaft diameter	D12	h7	40 (1.575)	63 (2.480)	80 (3.150)	100 (3.937)		
Centering diameter output flange	D13		64 (2.520)	90 (3.543)	110 (4.331)	140 (5.512)		
Flange diameter output	D14		86 (3.386)	118 (4.646)	145 (5.709)	179 (7.047)		
Mounting bore output	D16		4.5 7x45°	5.5 7x45°	5.5 7x45°	6.6 10x30°	1	
			4.5 8x45°	5.5 8x45°	5.5 8x45°	6.6 12x30°	2	
Pitch circle diameter output flange	D17		79 (3.110)	109 (4.291)	135 (5.315)	168 (6.614)		
Min. total length	L1		104.5 (4.114)	132 (5.197)	153.5 (6.043)	201.5 (7.933)	1	
			122.5 (4.823)	139.5 (5.492)	154 (6.063)	224 (8.819)	2	
Housing length	L2		42 (1.653)	53.5 (2.106)	68 (2.677)	76.5 (3.012)	1	
			59.5 (2.342)	66.5 (2.618)	76.5 (3.012)	129.5 (5.098)	2	
Flange thickness output	L8		4 (0.157)	7 (0.276)	8 (0.315)	10 (0.394)		
Offset length	L9		43 (1.693)	48.5 (1.909)	56.5 (2.224)	87 (3.425)	1	
			43 (1.693)	43 (1.693)	48.5 (1.909)	56.5 (2.224)	2	
Centering depth output shaft	L10		4.5 (0.177)	6.5 (0.256)	6.5 (0.256)	6.5 (0.256)		
	L11		3 (0.118)	6 (0.236)	6 (0.236)	6 (0.236)		
Centering depth output flange	L12		10 (0.394)	12 (0.472)	12 (0.472)	14 (0.551)		
Output flange length	L13		19.5 (0.760)	30.0 (1.181)	29.0 (1.142)	38.0 (1.496)		
Min. overall height	L23		179 (7.047)	210 (8.267)	260 (10.236)	323 (12.716)	1	
			179 (7.047)	195 (7.677)	223.5 (8.799)	277 (10.905)	2	
Motor shaft diameter j6/k6	D20		More information on page 155/156					
Clamping system diameter input	D26		More information on page 155/156					
Flange output hollow shaft with dowel hole (EN ISO 9409-1)								
Dowel hole x depth	D15	H7	5x5	6x6	6x6	8x8	1	H
Hollow shaft diameter	D24		17 (0.669)	25 (0.984)	35 (1.378)	50 (1.969)		
Number x thread x depth	G2		7 x M5x7	7 x M6x10	11 x M6x12	11 x M8x15		
Flange output shaft (similar EN ISO 9409-1)								
Number x thread x depth	G2		8 x M5x7	8 x M6x10	12 x M6x12	12 x M8x15	2	D
Flange output shaft with dowel hole (EN ISO 9409-1)								
Dowel hole x depth	D15	H7	5x5	6x6	6x6	8x8	2	E
Number x thread x depth	G2		7 x M5x7	7 x M6x10	11 x M6x12	11 x M8x15		

<sup>(2)</sup> Dimensions in mm

<sup>(3)</sup> Number of stages