

# WPLE

The versatile right angle planetary gearbox with lower weight and appealing cost effectiveness

The **WPLE** is a consistent continuation of the benefits offered by the Economy Line. With its compact, but powerful design, it is ideal for dynamic multiple axis systems. Our right angle gearbox features lifetime lubrication, is easy to install, all this at an unrivalled price-performance ratio.

Nominal output torque **5 - 260 Nm**



Radial force **200 - 1750 N**



Axial force **200 - 2500 N**

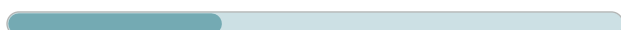

Torsional backlash **11 - 28 arcmin**

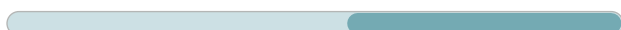

Protection class **IP54**



Frame sizes

- 40
- 60
- 80
- 120

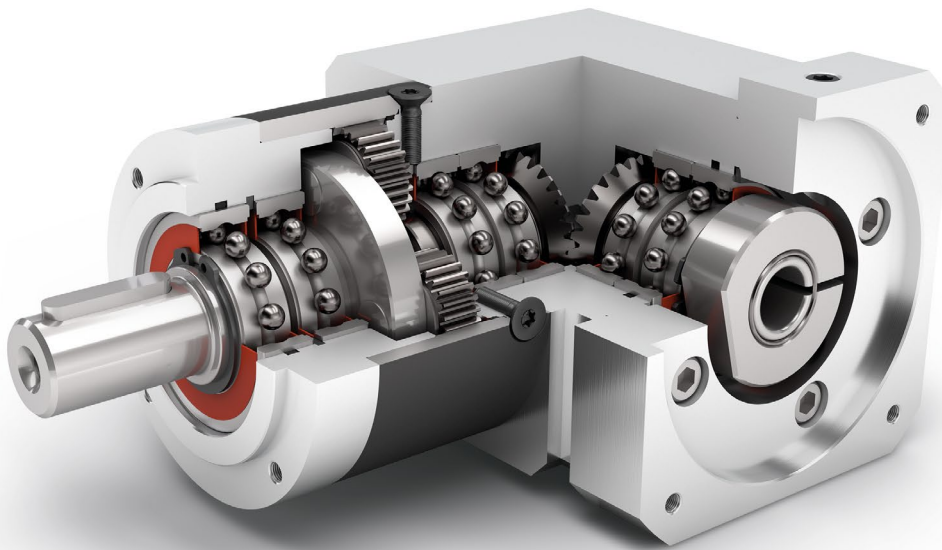

Economy Line



Right angle gearbox



Spur gear

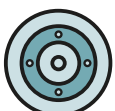

Round type output flange



High ratio variety  $i=3$  up to  $i=512$

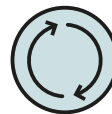

Equidirectional rotation



Bevel gear right angle stage



Low-friction deep groove ball bearings



Planet carrier in disc design

Detailed explanations of the technical features starting on page 169.

Code	Gearbox characteristics			WPLE040	WPLE060	WPLE080	WPLE120	p <sup>(1)</sup>
	Service life (L <sub>10h</sub> )	t <sub>L</sub>	h	20,000				
	Service life at T <sub>2N</sub> x 0,88			30,000				
	Efficiency at full load <sup>(2)</sup>	η	%	95				1
				94				2
				88				3
	Min. operating temperature	T <sub>min</sub>	°C (°F)	-25 (-13)				
	Max. operating temperature	T <sub>max</sub>		90 (194)				
	Protection class				IP54			
<b>S</b>	Standard lubrication				Grease (lifetime lubrication)			
<b>F</b>	Food grade lubrication				Grease (lifetime lubrication)			
<b>L</b>	Low temperature lubrication <sup>(3)</sup>				Grease (lifetime lubrication)			
	Installation position				Any			
<b>S</b>	Standard backlash	j <sub>t</sub>	arcmin	< 21	< 16	< 13	< 11	1
				< 25	< 18	< 15	< 13	2
				< 28	< 21	< 17	< 15	3
	Torsional stiffness <sup>(2)</sup>	c <sub>g</sub>	Nm /arcmin (lb <sub>r</sub> .in/ arcmin)	0.5 - 0.8 (4 - 7)	1.5 - 2.3 (13 - 20)	4.0 - 7.9 (35 - 70)	9.9 - 17.5 (88 - 155)	1
				0.7 - 1.0 (6 - 8)	2.2 - 2.7 (19 - 24)	6.9 - 9.6 (61 - 85)	16.4 - 20.5 (145 - 181)	2
				0.8 - 1.0 (7 - 9)	2.3 - 2.8 (20 - 25)	7.9 - 10.4 (70 - 92)	17.5 - 22.0 (155 - 195)	3
	Gearbox weight <sup>(2)</sup>	m <sub>G</sub>	kg (lb <sub>m</sub> )	0.6 (1.3)	1.6 (3.5)	3.7 (8.1)	9.6 - 9.8 (21.3 - 21.5)	1
				0.7 (1.5)	1.8 (4.0)	4.1 - 4.2 (9.1 - 9.3)	11.4 - 11.6 (25.1 - 25.5)	2
				0.7 - 0.8 (1.6 - 1.7)	2.0 (4.4)	4.6 - 4.7 (10.2 - 10.4)	13.2 - 13.4 (29.1 - 29.6)	3
<b>S</b>	Standard surface				Housing: Steel – heat-treated and post-oxidized (black)			
	Running noise <sup>(4)</sup>	Q <sub>g</sub>	dB(A)	68	70	73	75	
	Max. bending moment based on the gearbox input flange <sup>(5)</sup>	M <sub>b</sub>	Nm (lb <sub>r</sub> .in)	2 (18)	5 (44)	10.5 (93)	26 (230)	

Output shaft loads			WPLE040	WPLE060	WPLE080	WPLE120	p <sup>(1)</sup>
Radial force for 20,000 h <sup>(6)(7)</sup>	F <sub>r 20.000h</sub>	N (lb <sub>r</sub> )	200 (45)	400 (90)	750 (169)	1750 (393)	
Axial force for 20,000 h <sup>(6)(7)</sup>	F <sub>a 20.000h</sub>		200 (45)	500 (112)	1000 (225)	2500 (562)	
Radial force for 30,000 h <sup>(6)(7)</sup>	F <sub>r 30.000h</sub>		160 (36)	340 (76)	650 (146)	1500 (337)	
Axial force for 30,000 h <sup>(6)(7)</sup>	F <sub>a 30.000h</sub>		160 (36)	450 (101)	900 (202)	2100 (472)	
Maximum radial force <sup>(7)(8)</sup>	F <sub>r Stat</sub>		200 (45)	700 (157)	1250 (281)	2000 (450)	
Maximum axial force <sup>(7)(8)</sup>	F <sub>a Stat</sub>		240 (54)	800 (180)	1600 (360)	3800 (854)	
Tilting moment for 20,000 h <sup>(6)(8)</sup>	M <sub>K 20.000h</sub>	Nm (lb <sub>r</sub> .in)	5 (44)	14 (124)	31 (274)	101 (894)	
Tilting moment for 30,000 h <sup>(6)(8)</sup>	M <sub>K 30.000h</sub>		4 (35)	12 (106)	27 (239)	86 (761)	

Moment of inertia			WPLE040	WPLE060	WPLE080	WPLE120	p <sup>(1)</sup>
Mass moment of inertia <sup>(2)</sup>	J	kgcm <sup>2</sup> (lb <sub>r</sub> .in.s <sup>2</sup> 10 <sup>-4</sup> )	0.032 - 0.049 (0.283 - 0.434)	0.221 - 0.357 (1.956 - 3.160)	0.910 - 1.273 (8.054 - 11.267)	1.820 - 2.846 (16.108 - 25.189)	1
			0.032 - 0.048 (0.283 - 0.425)	0.222 - 0.350 (1.965 - 3.098)	0.916 - 1.232 (8.107 - 10.904)	1.855 - 2.773 (16.418 - 24.543)	2
			0.032 - 0.047 (0.283 - 0.416)	0.222 - 0.232 (1.965 - 2.053)	0.916 - 1.209 (8.107 - 10.701)	1.854 - 2.681 (16.409 - 23.729)	3

(1) Number of stages  
 (2) The ratio-dependent values can be retrieved in Tec Data Finder – www.neugart.com  
 (3) T<sub>min</sub> = -40°C. Optimal operating temperature max. 50°C  
 (4) Sound pressure level from 1 m, measured on input running at n<sub>i</sub>=3000 rpm no load; i=5  
 (5) Max. motor weight\* in kg = 0.2 x M<sub>g</sub> / motor length in m  
 \* with symmetrically distributed motor weight  
 \* with horizontal and stationary mounting  
 (6) These values are based on an output shaft speed of n<sub>2</sub>=100 rpm  
 (7) Based on center of output shaft  
 (8) Other (sometimes higher) values following changes to T<sub>2N</sub>, F<sub>r</sub>, F<sub>a</sub>, cycle, and service life of bearing. Application specific configuration with NCP – www.neugart.com

Output torques			WPLE040	WPLE060	WPLE080	WPLE120	i <sup>(1)</sup>	p <sup>(2)</sup>
Nominal output torque <sup>(3)(4)</sup>	T <sub>2N</sub>	Nm (lb <sub>r</sub> .in)	4,5 (40)	14 (124)	40 (354) <sup>(5)</sup>	80 (708) <sup>(5)</sup>	3	1
			6 (53)	19 (168)	53 (469) <sup>(5)</sup>	105 (929) <sup>(5)</sup>	4	
			7,5 (66)	24 (212)	67 (593) <sup>(5)</sup>	130 (1151) <sup>(5)</sup>	5	
			8,5 (75)	25 (221)	65 (575)	135 (1195)	7	
			6 (53)	18 (159)	50 (443)	120 (1062)	8	
			5 (44)	15 (133)	38 (336)	95 (841)	10	
			16,5 (146) <sup>(5)</sup>	44 (389) <sup>(5)</sup>	130 (1151) <sup>(5)</sup>	210 (1859) <sup>(5)</sup>	9	2
			20 (177) <sup>(5)</sup>	44 (389)	120 (1062) <sup>(5)</sup>	260 (2301) <sup>(5)</sup>	12	
			18 (159) <sup>(5)</sup>	44 (389)	110 (974)	230 (2036)	15	
			20 (177) <sup>(5)</sup>	44 (389)	120 (1062)	260 (2301)	16	
			20 (177) <sup>(5)</sup>	44 (389)	120 (1062)	260 (2301)	20	
			18 (159)	40 (354)	110 (974)	230 (2036)	25	
			20 (177)	44 (389)	120 (1062)	260 (2301)	32	3
			18 (159)	40 (354)	110 (974)	230 (2036)	40	
			7,5 (66)	18 (159)	50 (443)	120 (1062)	64	
			20 (177)	44 (389)	110 (974)	260 (2301)	60	
			20 (177)	44 (389)	120 (1062)	260 (2301)	80	
			20 (177)	44 (389)	120 (1062)	260 (2301)	100	
			18 (159)	44 (389)	110 (974)	230 (2036)	120	3
			20 (177)	44 (389)	120 (1062)	260 (2301)	160	
			18 (159)	40 (354)	110 (974)	230 (2036)	200	
			20 (177)	44 (389)	120 (1062)	260 (2301)	256	
			18 (159)	40 (354)	110 (974)	230 (2036)	320	
			7,5 (66)	18 (159)	50 (443)	120 (1062)	512	
Max. output torque <sup>(4)(6)</sup>	T <sub>2max</sub>	Nm (lb <sub>r</sub> .in)	7 (62)	22 (195)	64 (566)	128 (1133)	3	1
			10 (89)	30 (266)	85 (752)	168 (1487)	4	
			12 (106)	38 (336)	107 (947)	208 (1841)	5	
			13,5 (119)	40 (354)	104 (920)	216 (1912)	7	
			10 (89)	29 (257)	80 (708)	192 (1699)	8	
			8 (71)	24 (212)	61 (540)	152 (1345)	10	
			26 (230)	70 (620)	208 (1841)	336 (2974)	9	2
			32 (283)	70 (620)	192 (1699)	416 (3682)	12	
			29 (257)	70 (620)	176 (1558)	368 (3257)	15	
			32 (283)	70 (620)	192 (1699)	416 (3682)	16	
			32 (283)	70 (620)	192 (1699)	416 (3682)	20	
			29 (257)	64 (566)	176 (1558)	368 (3257)	25	
			32 (283)	70 (620)	192 (1699)	416 (3682)	32	3
			29 (257)	64 (566)	176 (1558)	368 (3257)	40	
			12 (106)	29 (257)	80 (708)	192 (1699)	64	
			32 (283)	70 (620)	176 (1558)	416 (3682)	60	
			32 (283)	70 (620)	192 (1699)	416 (3682)	80	
			32 (283)	70 (620)	192 (1699)	416 (3682)	100	
			29 (257)	70 (620)	176 (1558)	368 (3257)	120	3
			32 (283)	70 (620)	192 (1699)	416 (3682)	160	
			29 (257)	64 (566)	176 (1558)	368 (3257)	200	
			32 (283)	70 (620)	192 (1699)	416 (3682)	256	
			29 (257)	64 (566)	176 (1558)	368 (3257)	320	
			12 (106)	29 (257)	80 (708)	192 (1699)	512	

WPLE

(1) Ratios (i=n<sub>1</sub>/n<sub>2</sub>)  
 (2) Number of stages  
 (3) Application specific configuration with NCP – www.neugart.com  
 (4) Values for feather key (code "A"): for repeated load  
 (5) Different service life: 10,000 h at T<sub>2N</sub>  
 (6) 30,000 rotations of the output shaft permitted; see page 158

WPLE

Output torques			WPLE040	WPLE060	WPLE080	WPLE120	$i^{(1)}$	$p^{(2)}$
Emergency stop torque <sup>(3)</sup>	$T_{2Stop}$	Nm (lb <sub>r</sub> .in)	22,5 (199)	66 (584)	180 (1593)	360 (3186)	3	1
			28 (248)	86 (761)	240 (2124)	474 (4195)	4	
			35 (310)	80 (708)	220 (1947)	500 (4425)	5	
			26 (230)	80 (708)	178 (1575)	340 (3009)	7	
			27 (239)	80 (708)	190 (1682)	380 (3363)	8	
			25 (221)	70 (620)	170 (1505)	430 (3806)	10	2
			33 (292)	88 (779)	260 (2301)	500 (4425)	9	
			40 (354)	88 (779)	240 (2124)	520 (4602)	12	
			36 (319)	88 (779)	220 (1947)	500 (4425)	15	
			40 (354)	88 (779)	240 (2124)	520 (4602)	16	
			40 (354)	88 (779)	240 (2124)	520 (4602)	20	
			36 (319)	80 (708)	220 (1947)	500 (4425)	25	
			40 (354)	88 (779)	240 (2124)	520 (4602)	32	
			36 (319)	80 (708)	220 (1947)	500 (4425)	40	
			27 (239)	80 (708)	190 (1682)	380 (3363)	64	
			40 (354)	88 (779)	220 (1947)	520 (4602)	60	
			40 (354)	88 (779)	240 (2124)	520 (4602)	80	
			40 (354)	88 (779)	240 (2124)	520 (4602)	100	
			36 (319)	88 (779)	220 (1947)	500 (4425)	120	
			40 (354)	88 (779)	240 (2124)	520 (4602)	160	
36 (319)	80 (708)	220 (1947)	500 (4425)	200				
40 (354)	88 (779)	240 (2124)	520 (4602)	256				
36 (319)	80 (708)	220 (1947)	500 (4425)	320				
27 (239)	80 (708)	190 (1682)	380 (3363)	512				

Input speeds			WPLE040	WPLE060	WPLE080	WPLE120	$i^{(1)}$	$p^{(2)}$
Average thermal input speed at $T_{2N}$ and $S1^{(4)(5)}$	$n_{1N}$	rpm	5000	4500 <sup>(6)</sup>	3500 <sup>(6)</sup>	2850 <sup>(6)</sup>	3	1
			5000	4500 <sup>(6)</sup>	3550 <sup>(6)</sup>	2950 <sup>(6)</sup>	4	
			5000	4500 <sup>(6)</sup>	3600 <sup>(6)</sup>	3050 <sup>(6)</sup>	5	
			5000	4500	4000 <sup>(6)</sup>	3500 <sup>(6)</sup>	7	
			5000	4500	4000 <sup>(6)</sup>	3500 <sup>(6)</sup>	8	
			5000	4500	4000	3500	10	2
			5000	4500 <sup>(6)</sup>	3250 <sup>(6)</sup>	2950 <sup>(6)</sup>	9	
			5000	4500 <sup>(6)</sup>	3850 <sup>(6)</sup>	3050 <sup>(6)</sup>	12	
			5000	4500	4000 <sup>(6)</sup>	3500 <sup>(6)</sup>	15	
			5000	4500	4000 <sup>(6)</sup>	3450 <sup>(6)</sup>	16	
			5000	4500	4000 <sup>(6)</sup>	3500 <sup>(6)</sup>	20	
			5000	4500	4000	3500 <sup>(6)</sup>	25	
			5000	4500	4000	3500	32	
			5000	4500	4000	3500	40	
			5000	4500	4000	3500	64	
			5000	4500	4000	3500	80	
			5000	4500	4000	3500	100	
			5000	4500	4000	3500	120	
			5000	4500	4000	3500	160	
			5000	4500	4000	3500	200	
5000	4500	4000	3500	256				
5000	4500	4000	3500	320				
5000	4500	4000	3500	512				
Max. mechanical input speed <sup>(4)</sup>	$n_{1Limit}$	rpm	18000	13000	7000	6500		1
			18000	13000	7000	6500		2
			18000	13000	7000	6500		3

(1) Ratios ( $i=n_1/n_2$ )  
 (2) Number of stages  
 (3) Permitted 1000 times  
 (4) Application-specific speed configurations with NCP – www.neugart.com  
 (5) See page 158 for the definition  
 (6) Average thermal input speed at 50%  $T_{2N}$  and  $S1$

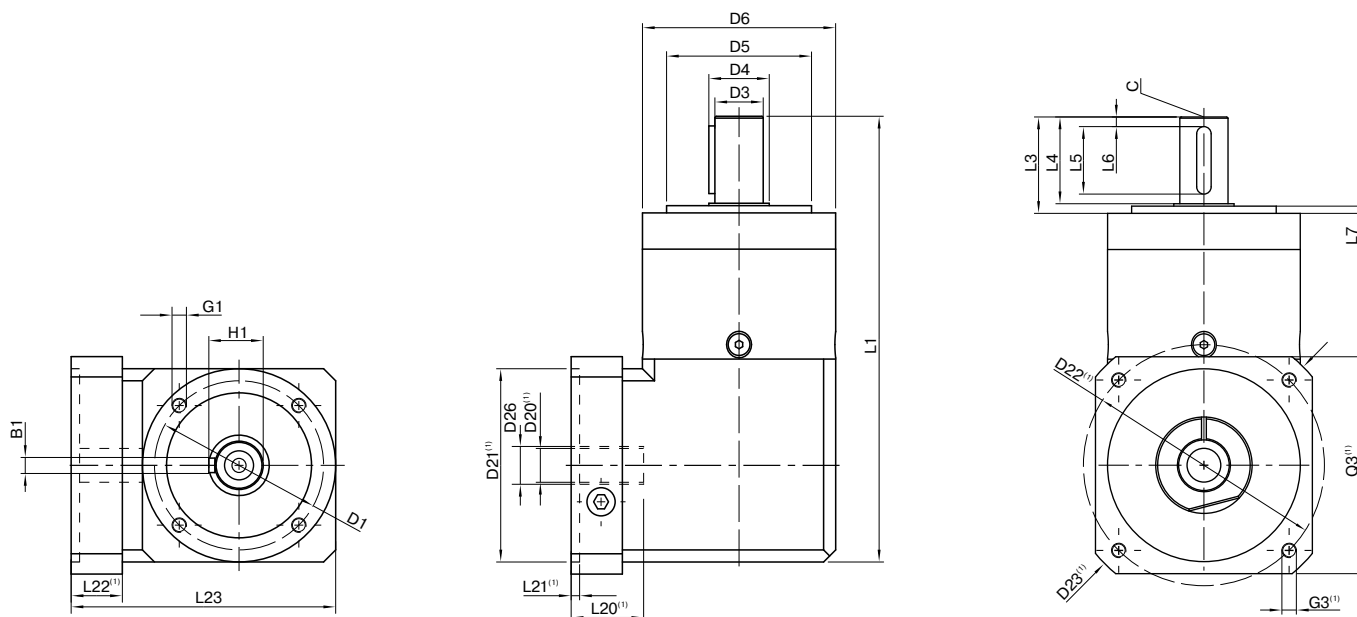

Drawing corresponds to a WPLE080 / 1-stage / output shaft with feather key / 19 mm clamping system / motor adaptation – 2-part – square universal flange / B5 flange type motor

<sup>(1)</sup> The dimensions vary with the motor/gearbox flange. The input flange dimensions can be retrieved for each specific motor in Tec Data Finder at [www.neugart.com](http://www.neugart.com)

Geometry <sup>(2)</sup>			WPLE040	WPLE060	WPLE080	WPLE120	p <sup>(3)</sup>	Code
Pitch circle diameter output	D1		34 (1.339)	52 (2.047)	70 (2.756)	100 (3.937)		
Shaft diameter output	D3	h7	10 (0.394)	14 (0.551)	20 (0.787)	25 (0.984)		
Shaft collar output	D4		12 (0.472)	17 (0.669)	25 (0.984)	35 (1.378)		
Centering diameter output	D5	h7	26 (1.024)	40 (1.575)	60 (2.362)	80 (3.150)		
Housing diameter	D6		40 (1.575)	60 (2.362)	80 (3.150)	115 (4.528)		
Mounting thread x depth	G1	4x	M4x6	M5x8	M6x10	M10x16		
			110 (4.331)	147 (5.787)	184 (7.244)	249.5 (9.823)	1	
			123 (4.843)	159.5 (6.280)	201.5 (7.933)	277 (10.906)	2	
Total length	L1		135.5 (5.335)	172 (6.772)	219 (8.622)	304.5 (11.988)	3	
		Shaft length output	L3	26 (1.024)	35 (1.378)	40 (1.575)	55 (2.165)	
Centering depth output	L7		2 (0.079)	3 (0.118)	3 (0.118)	4 (0.157)		
Min. overall height	L23		62 (2.441)	85,5 (3.366)	109,5 (4.311)	145,5 (5.728)		
Motor shaft diameter j6/k6	D20		More information on page 155/156					
Clamping system diameter input	D26		More information on page 155/156					
Output shaft with feather key (DIN 6885-1)			A 3x3x18	A 5x5x25	A 6x6x28	A 8x7x40		A
Feather key width (DIN 6885-1)	B1		3 (0.118)	5 (0.197)	6 (0.236)	8 (0.315)		
Shaft height including feather key (DIN 6885-1)	H1		11.2 (0.441)	16 (0.630)	22.5 (0.886)	28 (1.102)		
Shaft length from shoulder	L4		23 (0.906)	30 (1.181)	36 (1.417)	50 (1.969)		
Feather key length	L5		18 (0.709)	25 (0.984)	28 (1.102)	40 (1.575)		
Distance from shaft end	L6		2.5 (0.098)	2.5 (0.098)	4 (0.157)	5 (0.197)		
Center hole (DIN 332, type DR)	C		M3x9	M5x12.5	M6x16	M10x22		
Smooth output shaft								B
Shaft length from shoulder	L4		23 (0.906)	30 (1.181)	36 (1.417)	50 (1.969)		

<sup>(2)</sup> Dimensions in mm

<sup>(3)</sup> Number of stages