

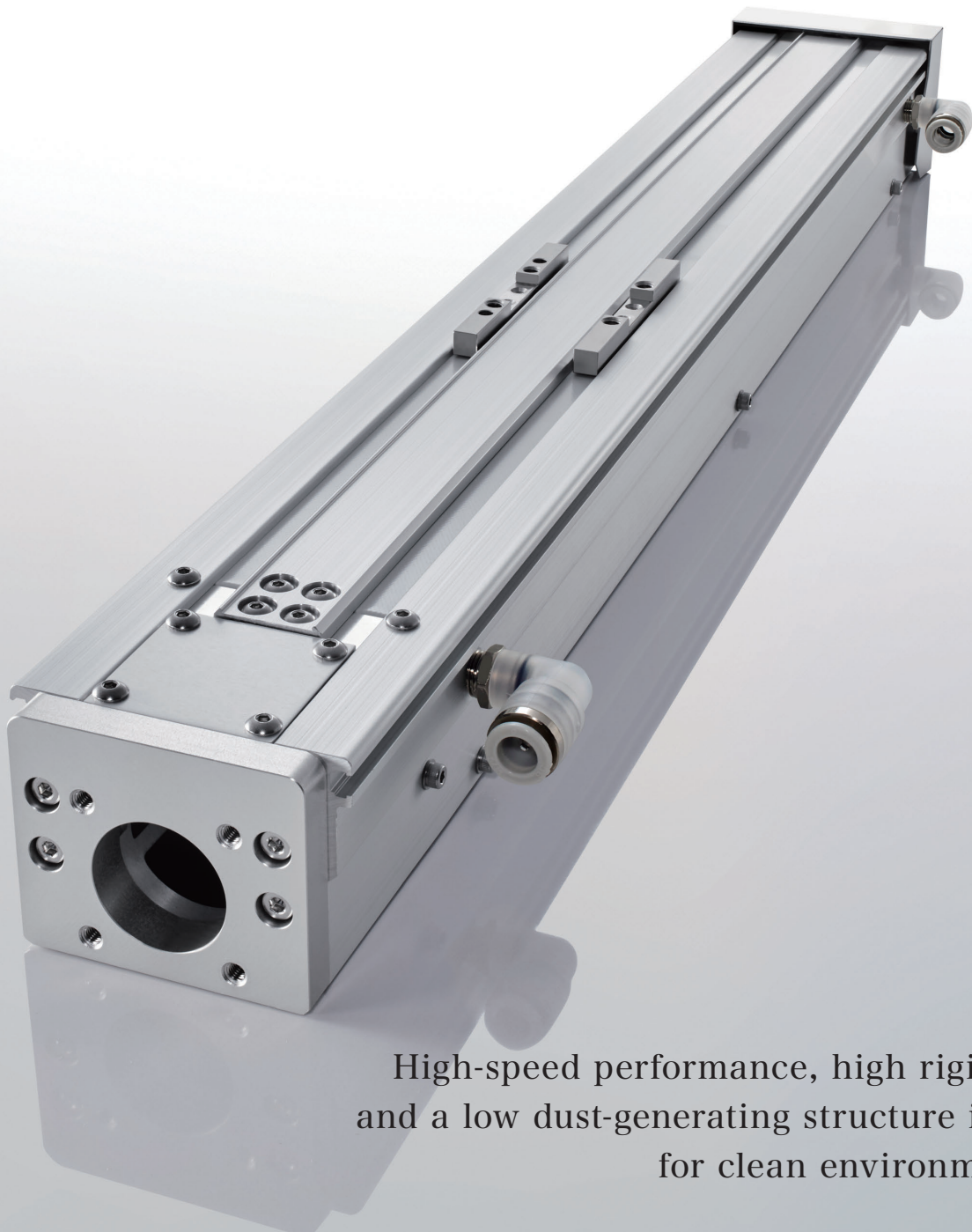

Clean Series
Caged Ball LM Guide Actuator

CSKR



High-speed performance, high rigidity,
and a low dust-generating structure ideal
for clean environments

For Clean Environments

CSKR

Low Dust-Generating
Caged Ball LM Guide Actuator

LM Guide Actuator with a low dust-generating structure ideal for clean environments.

The entire cover has a unique covering mechanism that uses a sealing sheet to achieve low dust generation.

CSKR20/26 achieves cleanliness (ISO14644-1¹) that is Class 3 equivalent,²

while CSKR33/46 achieves cleanliness (ISO14644-1¹) that is Class 4 equivalent.³

¹ ISO 14644-1:1999 is JIS B 9920 equivalent

² FED209D Class 1 equivalent

³ FED209D Class 10 equivalent

Note) Suction using suction ports is required to achieve Class 3 or Class 4.





Cleanliness

Class 3²

The unique cover mechanism

Sealing sheet

The sealing sheet on the top of the main unit results in a sealed structure with no openings, achieving Class 3 cleanliness through air suction inside the main body.

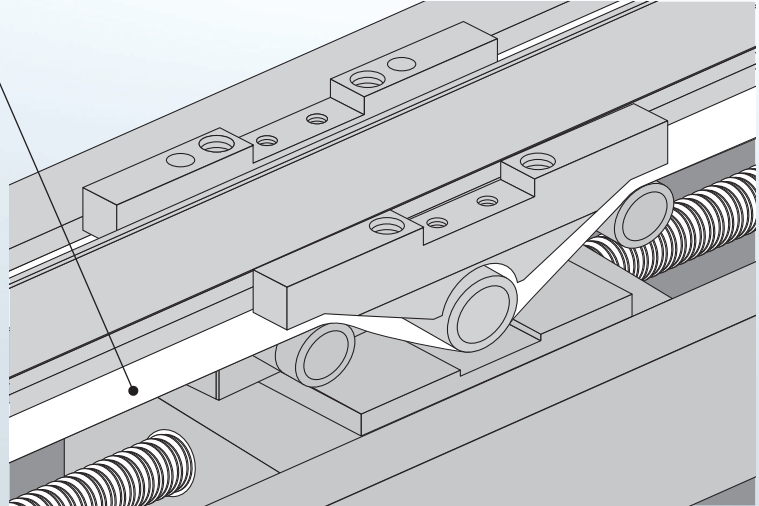

* Image is representative only

A: Slider

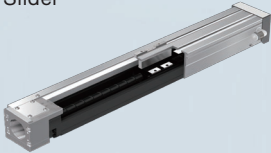

The interior uses 1 SKR block (A type).

B: Long slider



The interior uses 2 SKR blocks (B type), extending the total slider length.

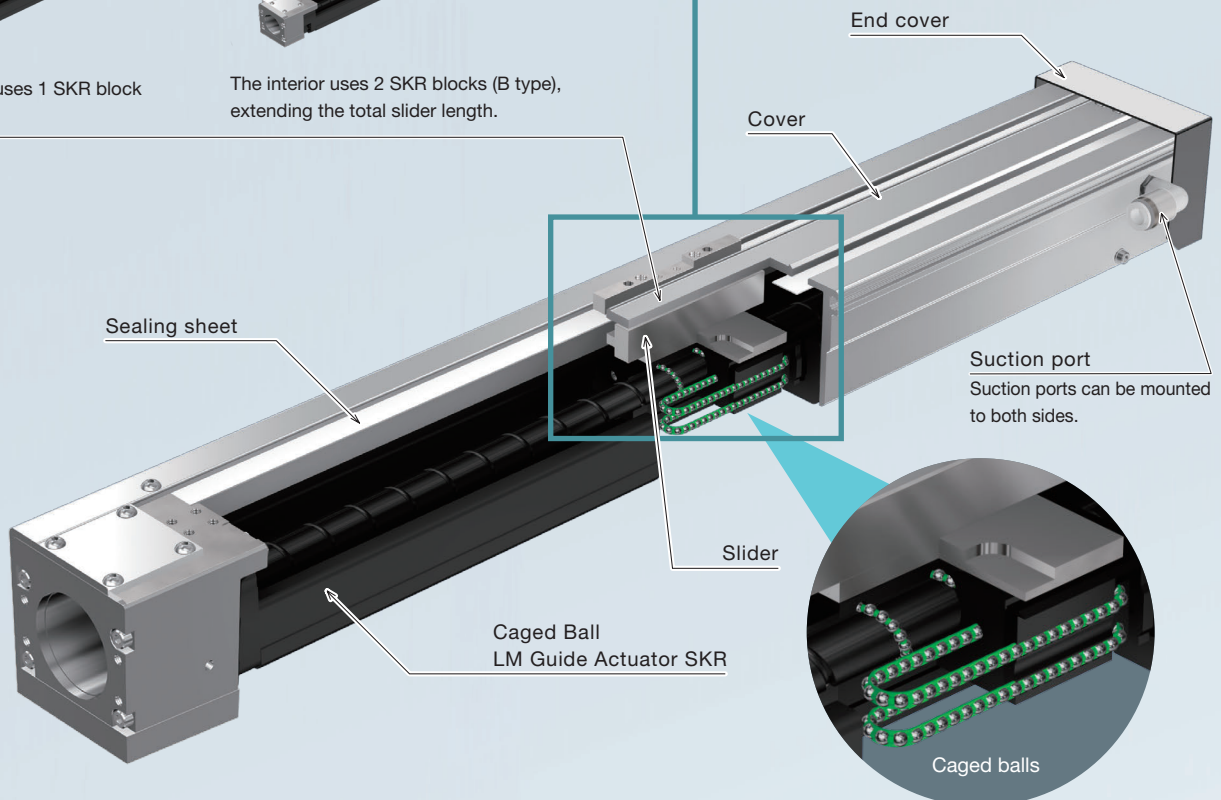

enables low dust generation.

Dust Generation Test

Test method

Test environment: In clean bench

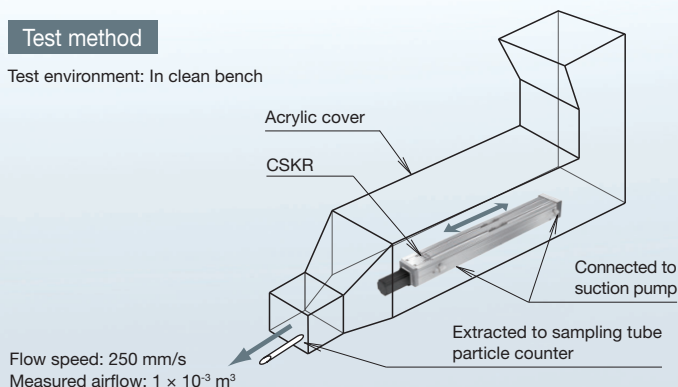

Test conditions

Item	Description
Model	CSKR3320B (Precision grade)
Stroke	289 mm
Speed	2000 mm/s
Acceleration/deceleration rate	14.7 m/s ² (1.5 G)
Vacuum rate	70 × 10 ⁻³ m ³ /min (70 L/min)
Applied load	None

Measurement conditions

Item	Description
Measuring equipment	Particle counter (KC-18 supplied by Rion Co., Ltd.)
Flow speed at measurement point	250 mm/s
Measured airflow	1 × 10 ⁻³ m ³ (1 L)
Measurement time	50 h

Test result

- Results after 50 hours of continuous operation (maximum speed 2000 mm/s)

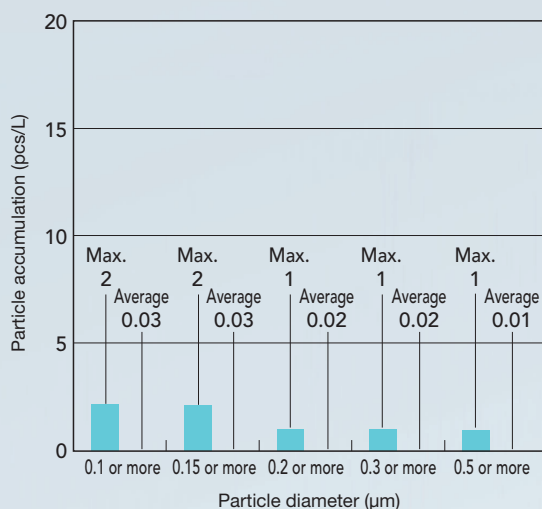

- Cleanliness class: ISO14644-1:1999

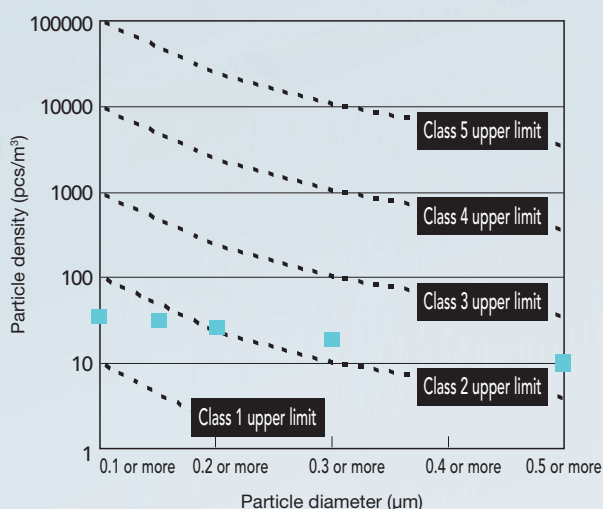

- Air cleanliness class evaluation results

Model	Stroke (mm)	Speed (mm/s)	Acceleration/deceleration rate (m/s ²)	Vacuum rate ¹ × 10 ⁻³ (m ³ /min)	Cleanliness ² (ISO14644-1:1999)
CSKR2006A	129	600	4.9	12	Class 3
CSKR2606A	206	600	4.9	24	Class 3
CSKR3320A	365	2000	14.7	56	Class 4
CSKR3320B	489	1200	4.9	60	Class 4
CSKR4620A	369	2000	14.7	80	Class 4
CSKR4620B	659	800	4.9	46	Class 4

¹ The vacuum rate does not include the effect of piping resistance. Piping resistance is dependent on the piping length and piping diameter, and can reduce the flow amount.

² The air cleanliness class varies with the operating conditions.

Note) Precision grade values.

Enables high-speed performance, high rigidity, and long-term maintenance-free operation.

THK Technology 1

High-Speed Performance

In ISO 14644-1¹ Class 4 (FED209D Class 10 equivalent)² environments, CSKR33/46 enable continuous operation up to a maximum speed of 2000 mm/s.³

¹ ISO 14644-1:1999 is JIS B 9920 equivalent.

² Suction using suction ports is required to achieve Class 3 or Class 4.

³ If using THK AFE-CA grease as lubricant.

Maximum speed **2000**³ mm/s

THK Technology 2

High Rigidity

Excellent high rigidity is achieved by using an outer rail with a U-shaped cross-section that enables a larger moment to be received.

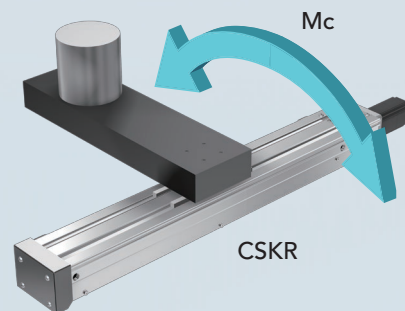
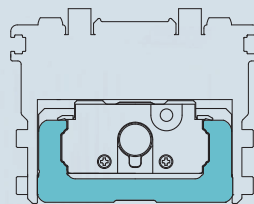

THK Technology 3

Caged Ball Technology

The structure rotates with the balls held within ball cages. This eliminates friction between balls, enabling motion with uniform alignment of the balls. Also, the spaces between the ball circulation parts and the ball cages (grease pockets) are filled with grease that covers the contact surfaces of the balls and ball cages as the balls rotate, continuously maintaining an oil film on the surfaces of the balls. This makes insufficient lubrication unlikely to occur.

This structure enables a long service life and long-term maintenance-free operation.

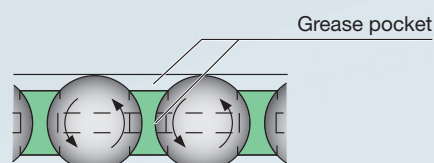
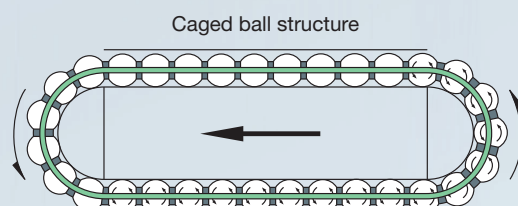
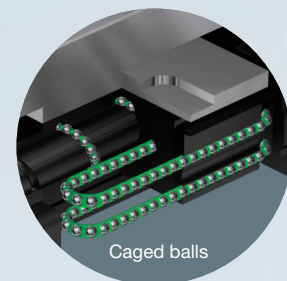

Used mainly in the electronic components industry, it is also suitable for transportation and inspection in pharmaceutical/food industry clean environments.

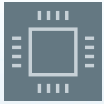

Electronic components industry
Wafer Palletizing

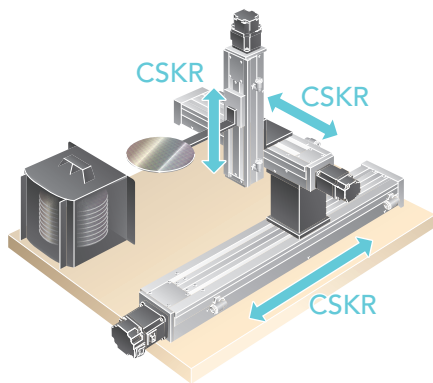

CSKR is used for wafer conveyor parts. A cleanliness Class 3 CSKR unit was selected due to the high level of cleanliness demanded. In addition, because of its high rigidity, a compact palletizing device with three orthogonal axes has been achieved.

Model used

X-axis: CSKR2606A
Y-axis: CSKR3310A
Z-axis: CSKR4610B

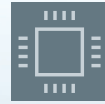

Electronic components industry
Liquid Crystal Glass Conveyor

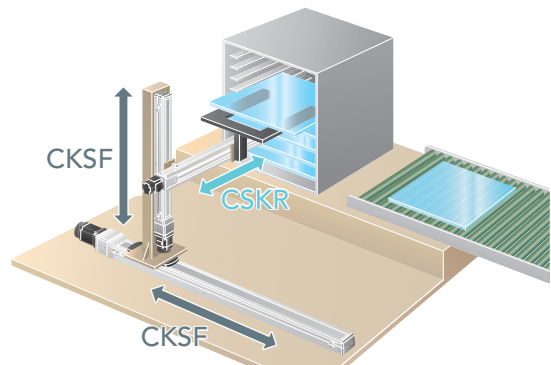

Liquid crystal glass conveyor parts use clean series actuators. Using a highly rigid CSKR of cleanliness Class 3 near the workpiece makes it possible to suppress both vibration of the workpiece and the amount of dust generation.

Model used

X-axis: CKSF10
Y-axis: CSKR2606A
Z-axis: CKSF6

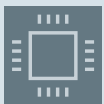

Electronic components industry
Electronic Component Conveyor Assembling Equipment

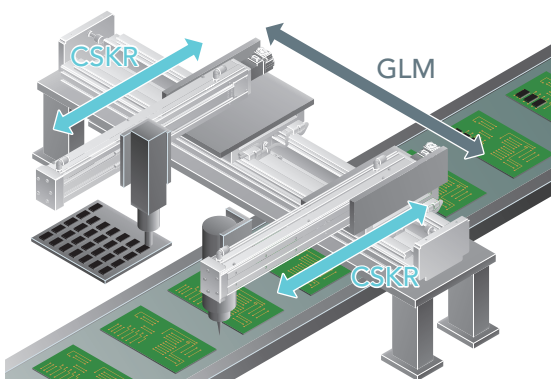

CSKR is used for electronic components conveyor assembling parts. High-speed performance and high rigidity enable quick and accurate positioning, dramatically improving productivity.

Model used

X-axis: GLM20AP
Y-axis: CSKR3320A

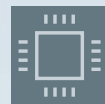

Electronic components industry
Substrate Laceration Inspection Device

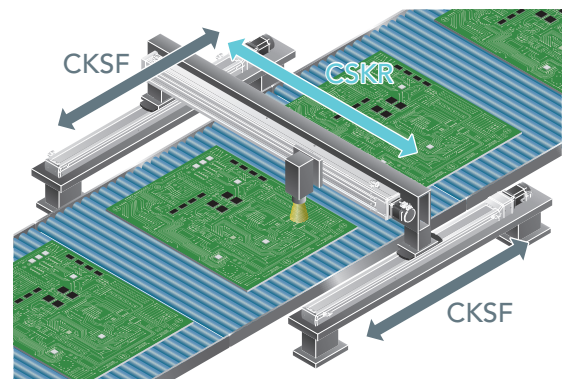

CSKR is used for the Y-axis and CKSF is used for the X-axis of the microscope for laceration inspection equipment. Using CSKR with Class 3 cleanliness, we have achieved a gate-type structure for large substrates.

Model used

X-axis: CKSF8
Y-axis: CSKR4620A

Series Lineup

Model	Ball screw lead (mm)	Stroke ¹ (mm)	Hypothetical motor capacity (W)	Maximum load capacity ² (kg)		
				Horizontal	Wall-mounted	Vertical
CSKR20	1	30 to 130	50	12.5	10	3
	6			12.5	10	6
CSKR26	2	60 to 210	50	27.5	22	14
	6			27.5	22	7
CSKR33	6	45 to 595	100	43.5	35	19
	10			34.5	30	12
	20			21	20	6
CSKR46	10	190 to 790	200	77	77	18
	20			41.5	41.5	8
	10		400	96	77	23
	20			90	54.5	18

¹ Stroke is the value with a slider (A type).

² Maximum load capacity is the weight at the speed and acceleration/deceleration rate as below.

Speed: Rated motor rotational speed 3000 min⁻¹

Acceleration and deceleration rate: 0.15 G for a lead less than 10 mm, 0.3 G for a lead of 10 mm, and 0.5 G for a lead of 20 mm

³ The maximum speed is limited by the actuator's permissible speed.

It is also the speed when the slider (A type) is selected.

Model Configuration

Model (1)	Ball screw lead (2)	Slider type (3)	Stroke (4)
CSKR26	06	A	0060
CSKR20	01: 1 mm	A: Slider	0030: 30 mm
CSKR26	02: 2 mm	B: Long slider	0060: 60 mm
CSKR33	06: 6 mm		0045: 45 mm
CSKR46	10: 10 mm		0080: 80 mm
	20: 20 mm		to
			0790: 790 mm

Ball screw leads that can be selected differ depending on the model.

CSKR20: "01," "06"

CSKR26: "02," "06"

CSKR33: "06," "10," "20"

CSKR46: "10," "20"

	Maximum speed for each stroke ³ (mm/s)											Product page
	Stroke ¹ (mm)											
	100	200	300	400	500	600	700	800	900	1000		
100												p. 9
600												
200												p. 15
600												
	600			550	390							p. 21
	1000			920	650							
	2000			1780	1270							
	1000				730	550	430					p. 27
	2000			1980	1430	1080	840					
	1000				730	550	430					
	2000			1980	1430	1080	840					

Accuracy grade (5)	With/without motor (6)
P	0
No symbol: Normal grade	0: Direct coupling (without motor)
H: High accuracy grade	1: Direct coupling (Specified motor prepared and mounted by THK)
P: Precision grade	

Sensors (7)	Intermediate flange (8)	Base plate (9)
6	A	N
0	A	N: No base plate
2	B	B: With base plate
6	C	
E	D	
J	E	
	G	
	H	
	I	
	J	

When selecting "0":
A coupling is not provided. Indicate when placing an order if a coupling is required.

When selecting "1":
The specified motor will be installed. Indicate the motor cable direction separately. Select (8) Intermediate flange to match the specified motor.

Motors from various manufacturers can be mounted.
Contact THK for details.

CSKR20

Main Unit Width 55 mm	Main Unit Height 39 mm	Stroke Max. 130 mm
---------------------------------	----------------------------------	------------------------------

Model Configuration

Model (1)	Ball screw lead (2)	Slider type (3)	Stroke (4)	Accuracy grade (5)	With/without motor (6)	Sensors (7)	Intermediate flange (8)	Base plate (9)
CSKR20	01	A	0030	P	0	6	A	N
CSKR20	01: 1 mm 06: 6 mm	A: Slider B: Long slider	0030: 30 mm to 0130: 130 mm	No symbol: Normal grade H: High accuracy grade P: Precision grade	0: Direct coupling (without motor) 1: Direct coupling (Specified motor prepared and mounted by THK) When selecting "0": A coupling is not provided. Indicate when placing an order if a coupling is required. When selecting "1": The specified motor will be installed. Indicate the motor cable direction separately. Select (8) Intermediate flange to match the specified motor.	0 2 6 E	A B C D	N: No base plate B: With base plate

Sensor details → p. 12 Intermediate flange details → p. 13

(3) Slider type

A: Slider
(A type)



The interior uses 1 SKR block (A type).

B: Long slider
(B type)



The interior uses 2 SKR blocks (B type), extending the total slider length.

Selection Materials

Basic Specifications

LM Guide	Basic dynamic load rating C (N)		6010
	Basic static load rating C ₀ (N)		8030
	Radial clearance (mm)	Normal grade/High accuracy grade (H)	-0.004 to 0
		Precision grade (P)	-0.006 to -0.004
	Geometrical moment of inertia	I _x ¹ (mm ⁴)	6 x 10 ³
I _y ² (mm ⁴)		6.14 x 10 ⁴	
Weight (kg/m)		2.6	
Ball screw	Ball screw lead (mm)		1 6
	Basic dynamic load rating C _a (N)	Normal grade/High accuracy grade (H)	860
		Precision grade (P)	1060
	Basic static load rating C _{0a} (N)	Normal grade/High accuracy grade (H)	1450
		Precision grade (P)	1600
	Screw shaft diameter (mm)		φ6
	Thread minor diameter (mm)		φ5.3 φ5
	Ball center-to-center diameter (mm)		φ6.15 φ6.3
	Permissible rotational speed ³ (min ⁻¹)	Normal grade/High accuracy grade (H)	6000
		Precision grade (P)	
Bearing (Fixed side)	Axial direction	Basic dynamic load rating C _a (N)	1150
		Static permissible load P _{0a} (N)	735
Permissible input torque (N·m)		0.12 0.42	
Static permissible moment ⁴ (N·m)		M _A : 38 (207), M _B : 38 (207) M _C : 28 (55)	
Running life ⁵ (km)		3,000 5,000	
Standard grease/Grease nipple used		THK AFE-CA Grease/PB107	
Guideline value of vacuum rate ⁶ × 10 ⁻³ (m ³ /min)		3 to 12	

¹ I_x = Geometrical moment of inertia of area around the X-axis.

² I_y = Geometrical moment of inertia of area around the Y-axis.

³ Permissible rotational speed may decrease if the stroke is lengthened.

⁴ The value in parentheses is with a long slider (B type).

⁵ The conditions for calculation are as follows:

Stroke: 80 mm (A type), 85 mm (B type). Speed: 50 mm/s (for 1 mm lead), 300 mm/s (for 6 mm lead). Load mass: maximum load capacity (see p. 7). Acceleration and deceleration rate: acceleration and deceleration rate when maximum load capacity is set (see p. 7). Center of gravity: center of the table upper surface.

⁶ The vacuum rate does not include the effect of piping resistance.

Note 1) LM Guide load rating is the load rating for the slider (A type).

Accuracy

Accuracy grade	Item	Stroke ⁷		
		30	80	130
Normal grade (no symbol)	Positioning repeatability (mm)	±0.01		
	Positioning accuracy (mm)	Not specified		
	Running parallelism (vertical direction) (mm)	Not specified		
	Backlash (mm)	0.02		
	Starting torque (N·cm)	0.8		

Accuracy grade	Item	Stroke ⁷		
		30	80	130
High accuracy grade (H)	Positioning repeatability (mm)	±0.005		
	Positioning accuracy (mm)	0.06		
	Running parallelism (vertical direction) (mm)	0.025		
	Backlash (mm)	0.01		
	Starting torque (N·cm)	0.8		

Accuracy grade	Item	Stroke ⁷		
		30	80	130
Precision grade (P)	Positioning repeatability (mm)	±0.003		
	Positioning accuracy (mm)	0.02		
	Running parallelism (vertical direction) (mm)	0.01		
	Backlash (mm)	0.003		
	Starting torque (N·cm)	1.9		

⁷ Stroke with a slider (A type).

Note 2) Precision evaluation in accordance with THK standards.

Note 3) Measured using a motor for inspection.

Note 4) The starting torque represents the value when containing THK AFE-CA Grease.

Note 5) Contact THK for accuracy higher than the standard stroke.

Geometrical moment of inertia

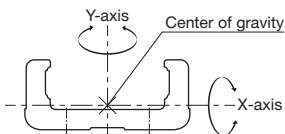

Static permissible moment

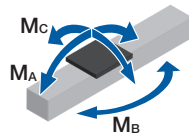

Motor Selection Specifications

Stroke ¹ (mm)	Outer rail length (mm)	LM Guide		Ball screw		Motor mounting part
		Weight of moving element (kg)	Sliding resistance value ² (N)	Lead (mm)	Shaft length (mm)	Shaft end diameter (mm)
30 to 130	100 to 200	A type 0.15 B type 0.44	4.8	1, 6	133 to 233	φ4h7

¹ Stroke with a slider (A type).

² Value with a slider (A type). This value is the sum of the rolling resistance value and seal resistance value.

Note) Refer to page 13 for applicable couplings.

Permissible Overhang Length³

Horizontal Usage

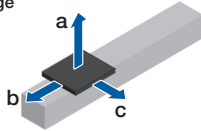

Wall-Mounted Usage

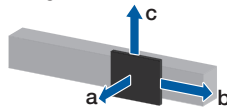

Vertical Usage

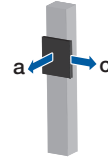

Hypothetical motor capacity 50 W		Ball screw lead (mm)	Load mass (kg)	a (mm)	b (mm)	c (mm)
Direct coupling	A type	1	3	400	110	330
			6	400	50	150
			12.5	400	20	70
	6	3	400	110	260	
			6	300	50	130
			12.5	130	20	60
B type	1	4	400	400	400	
			8.5	400	210	230
			17.5	400	100	110
	6	4	400	400	400	
			8.5	400	210	210
			17.5	400	100	100

Hypothetical motor capacity 50 W		Ball screw lead (mm)	Load mass (kg)	a (mm)	b (mm)	c (mm)
Direct coupling	A type	1	2.5	380	130	400
			5	170	60	400
			10	60	20	400
	6	2.5	310	130	400	
			5	130	50	350
			10	50	20	130
B type	1	3.5	400	400	400	
			7	260	240	400
			14	110	100	400
	6	3.5	400	400	400	
			7	250	240	400
			14	100	100	400

Hypothetical motor capacity 50 W		Ball screw lead (mm)	Load mass (kg)	a (mm)	c (mm)
Direct coupling	A type	1	0.5	400	400
			1.5	220	220
			3	90	90
	6	1.5	210	210	
			3	90	90
			6	30	30
B type	1	0.5	400	400	
			1.5	400	400
			3	400	400
	6	1.5	400	400	
			3	400	400
			6.5	260	260

³ Value when LM Guide running life is restricted to 5,000 km (3,000 km for 1 mm lead only). The calculation conditions are as follows.

Stroke: 80 mm (A type), 60 mm (B type). Acceleration/deceleration rate: 0.3 G. Speed: 50 mm/s (for 1 mm lead), 300 mm/s (for 6 mm lead). Overhang direction: Load in one direction only. Dimensions a, b, and c are the dimensions from the center of the table upper surface.

Dimensions

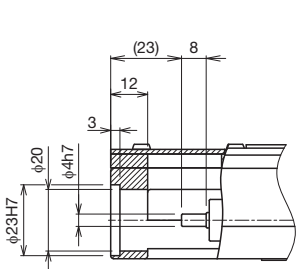
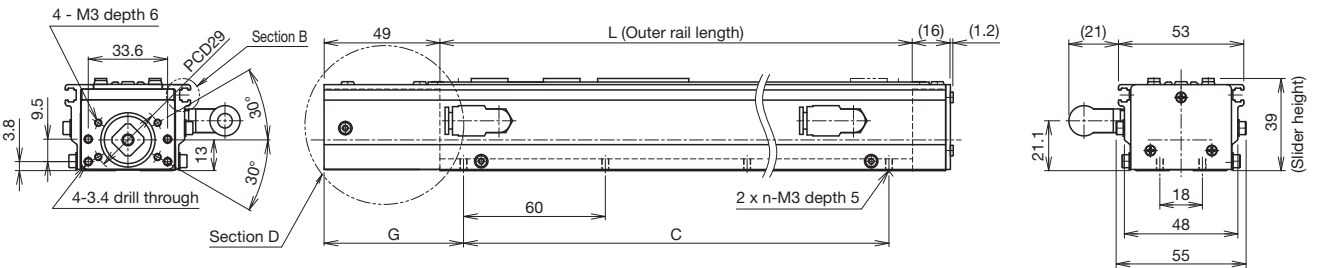
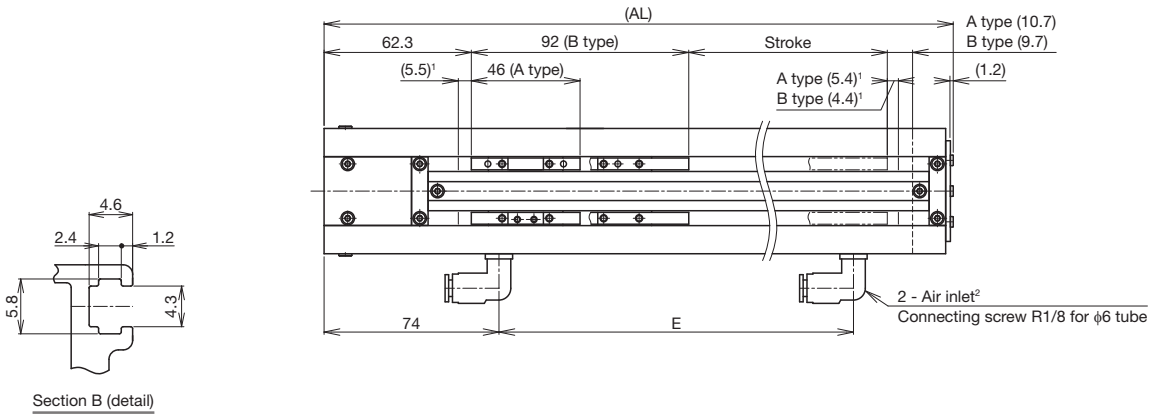

Section D details (details of motor mounting part)

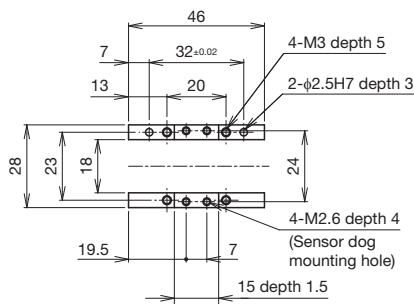

Slider (A type) details

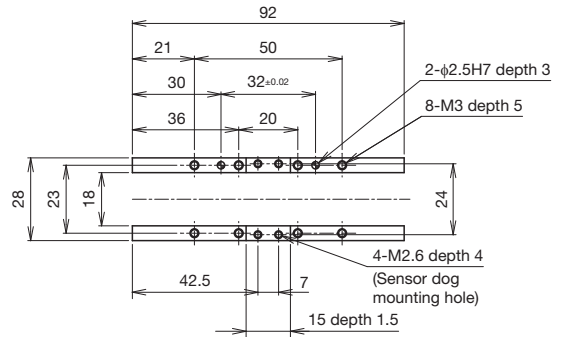

Long slider (B type) details

¹ Dimensions from the mechanical stopper to the stroke start position.
² Suction ports can be mounted from either side. Plug any unused suction ports. Two plugs are included.

Stroke (mm) (Stroke between mechanical stoppers)	A type	30 (40.9)	80 (90.9)	130 (140.9)
		B type	-	35 (44.9)
Maximum speed ³ (mm/s)	Ball screw lead: 1 mm		100	
	Ball screw lead: 6 mm		600	
Dimensions (mm)	AL	166.2	216.2	266.2
	L	100	150	200
	G	69	64	59
	C	60	120	180
Mounting hole count	n	2	3	4
	Weight ⁴ (kg)	0.9	1	1.2

³ Maximum speed is limited by the actuator's permissible speed.

⁴ The weight with a long slider (B type) has 0.29 kg added.

Options

Sensors

Optional photo sensors and proximity sensors are available. Keep the following precautions (Notes 1 to 5) in mind for use. Various sensors can be mounted using the T-slot in the side cover.

Symbol	Description	Model	Accessories
0	None	-	-
2	Photo sensor ¹ (x3)	EE-SX671 (OMRON Corporation)	Mounting screws, nuts, sensor dog (x1 or 2), mounting plates (x3), connectors (EE-1001 x3)
6	Photo sensor ¹ (x3)	EE-SX674 (OMRON Corporation)	Mounting screws, nuts, sensor dog (x1 or 2), mounting plates (x3), connectors (EE-1001 x3)
E	Proximity sensor NO contact ² (x1) NC contact ³ (x2)	APM-D3A1-001 (Azbil Corporation) APM-D3B1-003 (Azbil Corporation)	Mounting screws, nuts, sensor dog (x1 or 2)

¹ The photo sensors can be switched between ON when lit and ON when unlit.

² NO contact: Normally open contact point

³ NC contact: Normally closed contact point

- Note 1) The sensor accessories are supplied with the actuator unit. To be mounted by the customer.
- Note 2) If proximity sensors are placed too close to each other, they may not work properly. In this case, provide sensors with variant frequencies. (For specifications, contact each manufacturer.)
- Note 3) For a stroke less than 70 mm, 2 sensor dogs are included.
- Note 4) The sensor output is all NPN output.
- Note 5) Mounting of sensors other than those in the table above is possible. Contact THK for details.

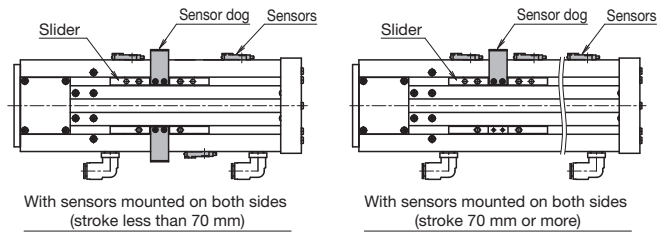
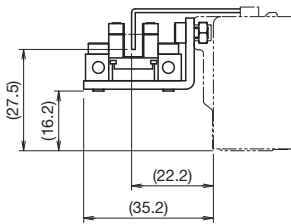
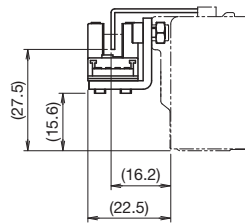

Photo Sensor Mounting Dimensions



Symbol	Model	Manufacturer
2	EE-SX671	OMRON Corporation

Sensor dog width: 14 mm



Symbol	Model	Manufacturer
6	EE-SX674	OMRON Corporation

Sensor dog width: 14 mm

Proximity Sensor Mounting Dimensions

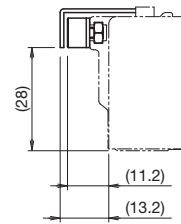

Symbol	Model	Manufacturer
E	APM-D3A1-001	Azbil Corporation
	APM-D3B1-003	

Sensor dog width: 14 mm

Base Plate

The height with the optional base plate mounted is the same as the conventional product (CKR).

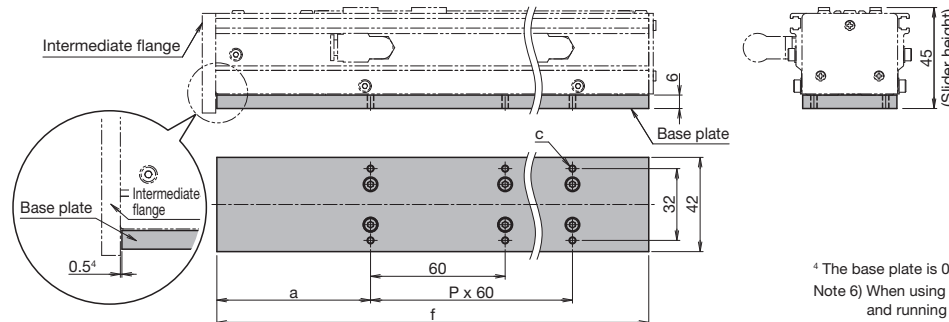

⁴ The base plate is 0.5 mm shorter than the end of the intermediate flange.
 Note 6) When using the base plate, the accuracy grade positioning accuracy and running parallelism (vertical direction) are equivalent to the normal grade (no symbol).

Stroke ⁵ (mm)	a (mm)	P	c	f (mm)
30	68.5	1	4 x M3 Helisert 1.5 D	162.5
80	63.5	2	6 x M3 Helisert 1.5 D	212.5
130	58.5	3	8 x M3 Helisert 1.5 D	262.5

⁵ Stroke with a slider (A type).

Options

Intermediate Flange

Intermediate flanges are available to mount various kinds of motors.
Specify an intermediate flange that matches the motor used.

Compatibility Table: Motors used, intermediate flanges, and couplings

Motor type	Manufacturer	Series	Motor model	Motor rated output (W)	Flange angle	Intermediate flange	Applicable coupling model		
							Miki Pulley Co., Ltd.	Nabeya Bi-tech Kaisha (NBK)	
AC servo motor	Yaskawa Electric Corporation	Σ-V	SGMJV-A5	50	□40	A	SFC-010DA2-4B-8B	XGT2-19C-4-8	
			SGMAV-A5						
		Σ-7	SGM7J-A5	50	□40	A			
			SGM7A-A5						
	Mitsubishi Electric Corporation	MELSERVO	J4	HG-KR053	50	□40			A
				HG-MR053					
			JN	HF-KN053					
	Tamagawa Seiki Co., Ltd.	TBL-iii	TS4602	50	□40	A			
		TBL-iv	TSM3102						
	Panasonic Corporation	MINAS	A5	MSMD5A	50	□38			B
				MSME5A					
			A6	MSMF5A	50	□38			B
				MHMF5A					
	Keyence Corporation	SV	SV-M005	50	□40	A			
SV2		SV2-M005							
Sanyo Denki Co., Ltd.	SANMOTION R	R2□A04005	50	□40	A				
OMRON Corporation	OMNUC G5	R88M-K05030	50	□40	A				
Fanuc Corporation	β is Series	βis0.2/5000	50	□40	A				

Motor type	Manufacturer	Series	Motor model	Flange angle	Intermediate flange	Applicable coupling model		
						Miki Pulley Co., Ltd.	Nabeya Bi-tech Kaisha (NBK)	
Stepper motor	Oriental Motor Co. Ltd.	α step	AZ2*, AR2*	□28	C	SFC-010DA2-4B-5B-L29	XGT2-15C-4-5	
			AZ4*, AR4* (excluding AZM48)	□42	D	SFC-010DA2-4B-6B	XGT2-15C-4-6	
			AZM48	□42	D	SFC-010DA2-4B-8B	XGT2-19C-4-8	
		5-phase	CRK	CRK52*	□28	C	SFC-010DA2-4B-5B-L29	XGT2-15C-4-5
				CRK54*	□42	D	SFC-010DA2-4B-5B	
			RKII	RKS54*	□42	D	SFC-010DA2-4B-6B	XGT2-15C-4-6
				PKA	PKA544	□42	D	SFC-010DA2-4B-5B
			CVK	PKP52*	□28	C	SFC-010DA2-4B-5B-L29	XGT2-15C-4-5
				PKP54*	□42	D	SFC-010DA2-4B-5B	
		2-phase	CVK	PKP22*	□28	C	SFC-010DA2-4B-5B-L29	XGT2-15C-4-5
				PKP24*	□42	D	SFC-010DA2-4B-5B	
		Keyence Corporation	2-phase	QS-M28	□28	C	SFC-010DA2-4B-5B-L29	XGT2-15C-4-5
	QS-M42			□42	D	SFC-010DA2-4B-5B		
	Sanyo Denki Co., Ltd.	PB	PBDM28*	□28	C	SFC-010DA2-4B-5B	XGT2-15C-4-5	
			PBDM423, PBA**423	□42	D	SFC-010DA2-4B-6B	XGT2-15C-4-6	
		5-phase	FAF/DF52*	□28	C	SFC-010DA2-4B-5B-L29	XGT2-15C-4-5	
			FAF54*/FDF54*/FA511M42/FB511M42	□42	D	SFC-010DA2-4B-6B	XGT2-15C-4-6	
		2-phase	D*14S28*	□28	C	SFC-010DA2-4B-5B-L29	XGT2-15C-4-5	
DB14H52*			□42	D	SFC-010DA2-4B-5B	XGT2-15C-4-5		
DU15H52*								

Note 1) Motor model number in the table shows the main part of the model number only. For details about models, please refer to the catalogs from each motor manufacturer.
 Note 2) If the maximum torque for motors exceeds the permissible input torque (see page 9), establish safety measures to limit torque.
 Note 3) When installing a motor other than the motor model numbers listed above, contact THK.

CSKR20
A

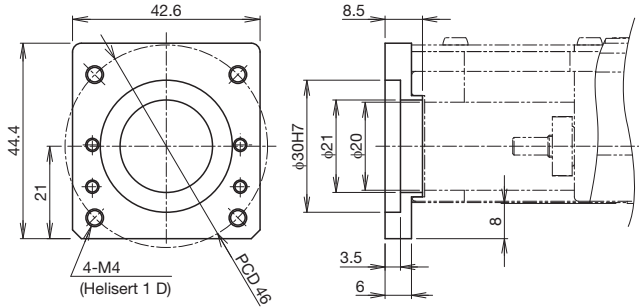

CSKR20
B

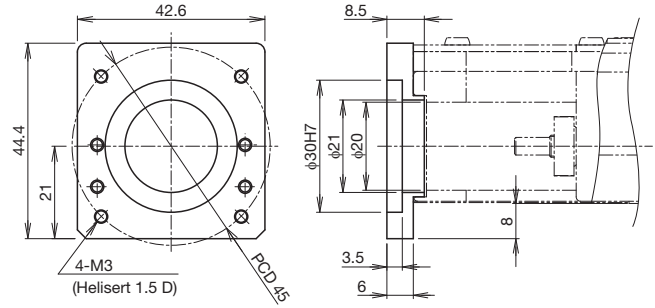

CSKR**	Actuator model
◇	◇: Intermediate flange

CSKR20
C

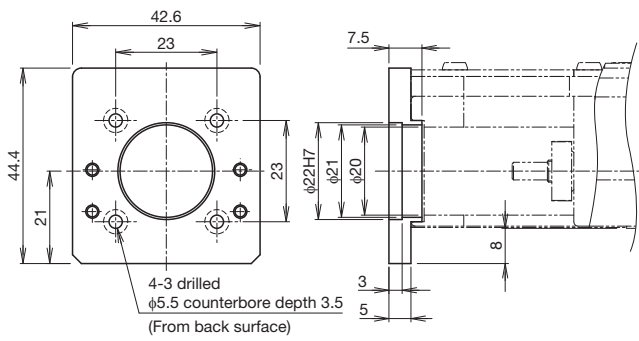

CSKR20
D

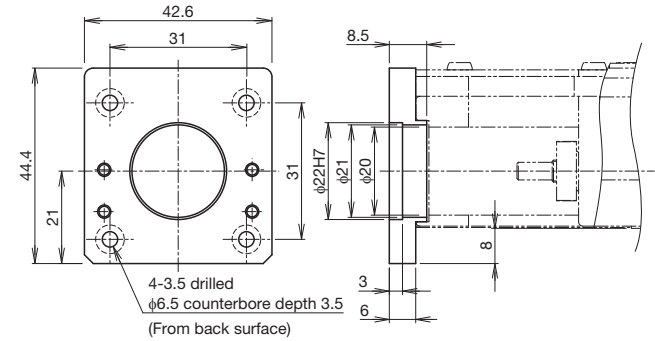

CSKR26

Main Unit Width 64 mm	Main Unit Height 50 mm	Stroke Max. 210 mm
---------------------------------	----------------------------------	------------------------------

Model Configuration

Model (1)	Ball screw lead (2)	Slider type (3)	Stroke (4)	Accuracy grade (5)	With/without motor (6)	Sensors (7)	Intermediate flange (8)	Base plate (9)
CSKR26	06	A	0060	P	0	6	A	N
CSKR26	02: 2 mm 06: 6 mm	A: Slider B: Long slider	0060: 60 mm to 0210: 210 mm	No symbol: Normal grade H: High accuracy grade P: Precision grade	0: Direct coupling (without motor) 1: Direct coupling (Specified motor prepared and mounted by THK)	0 2 6 E	A B C	N: No base plate B: With base plate

When selecting "0":
A coupling is not provided. Indicate when placing an order if a coupling is required.

When selecting "1":
The specified motor will be installed. Indicate the motor cable direction separately. Select (8) Intermediate flange to match the specified motor.

Sensor details → p. 19
→ p. 18

(3) Slider type

A: Slider
(A type)



The interior uses 1 SKR block (A type).

B: Long slider
(B type)



The interior uses 2 SKR blocks (B type), extending the total slider length.

Selection Materials

Basic Specifications

LM Guide	Basic dynamic load rating C (N)		13000
	Basic static load rating C ₀ (N)		16500
	Radial clearance (mm)	Normal grade/High accuracy grade (H)	-0.006 to 0
		Precision grade (P)	-0.007 to -0.006
	Geometrical moment of inertia	I _x ¹ (mm ⁴)	1.66 × 10 ⁴
I _y ² (mm ⁴)		1.48 × 10 ⁵	
Weight (kg/m)		3.9	
Ball screw lead (mm)		2 6	
Ball screw	Basic dynamic load rating Ca (N)	Normal grade/High accuracy grade (H)	2350 1950
		Precision grade (P)	2390
	Basic static load rating C _{0a} (N)	Normal grade/High accuracy grade (H)	4020 3510
		Precision grade (P)	3900
	Screw shaft diameter (mm)		φ8
	Thread minor diameter (mm)		φ6.6 φ6.7
Ball center-to-center diameter (mm)		φ8.3 φ8.4	
Permissible rotational speed ³ (min ⁻¹)	Normal grade/High accuracy grade (H)	6000	
	Precision grade (P)	6000	
Bearing (Fixed side)	Axial direction	Basic dynamic load rating Ca (N)	2000
		Static permissible load P _{0a} (N)	1230
Permissible input torque (N·m)		0.43	0.80
Static permissible moment ⁴ (N·m)		M _A : 117 (589), M _B : 117 (589), M _C : 38 (80)	
Running life ⁵ (km)		3,000	5,000
Standard grease/Grease nipple used		THK AFE-CA Grease/PB107	
Guideline value of vacuum rate ⁶ × 10 ⁻³ (m ³ /min)		4 to 14	

¹ I_x = Geometrical moment of inertia of area around the X-axis.

² I_y = Geometrical moment of inertia of area around the Y-axis.

³ Permissible rotational speed may decrease if the stroke is lengthened.

⁴ The value in parentheses is with a long slider (B type).

⁵ The conditions for calculation are as follows:

Stroke: 160 mm (A type), 95 mm (B type). Speed: 100 mm/s (for 2 mm lead), 300 mm/s (for 6 mm lead). Load mass: maximum load capacity (see p. 7). Acceleration and deceleration rate: acceleration and deceleration rate when maximum load capacity is set (see p. 7). Center of gravity: center of the table upper surface.

⁶ The vacuum rate does not include the effect of piping resistance.

Note 1) LM Guide load rating is the load rating for the slider (A type).

Accuracy

Accuracy grade	Item	Stroke ⁷			
		60	110	160	210
Normal grade (no symbol)	Positioning repeatability (mm)	±0.01			
	Positioning accuracy (mm)	Not specified			
	Running parallelism (vertical direction) (mm)	Not specified			
	Backlash (mm)	0.02			
	Starting torque (N·cm)	2.3			

Accuracy grade	Item	Stroke ⁷			
		60	110	160	210
High accuracy grade (H)	Positioning repeatability (mm)	±0.005			
	Positioning accuracy (mm)	0.06			
	Running parallelism (vertical direction) (mm)	0.025			
	Backlash (mm)	0.01			
	Starting torque (N·cm)	2.3			

Accuracy grade	Item	Stroke ⁷			
		60	110	160	210
Precision grade (P)	Positioning repeatability (mm)	±0.003			
	Positioning accuracy (mm)	0.02			
	Running parallelism (vertical direction) (mm)	0.01			
	Backlash (mm)	0.003			
	Starting torque (N·cm)	6.1			

⁷ Stroke with a slider (A type).

Note 2) Precision evaluation in accordance with THK standards.

Note 3) Measured using a motor for inspection.

Note 4) The starting torque represents the value when containing THK AFE-CA Grease.

Note 5) Contact THK for accuracy higher than the standard stroke.

Geometrical moment of inertia

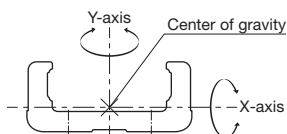

Static permissible moment

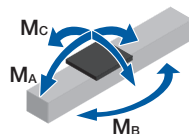

Motor Selection Specifications

Stroke ¹ (mm)	Outer rail length (mm)	LM Guide		Ball screw		Motor mounting part
		Weight of moving element (kg)	Sliding resistance value ² (N)	Lead (mm)	Shaft length (mm)	Shaft end diameter (mm)
60 to 210	150 to 300	A type 0.38 B type 0.85	4.8	2, 6	190 to 340	φ5h7

¹ Stroke with a slider (A type).

² Value with a slider (A type). This value is the sum of the rolling resistance value and seal resistance value.

Note) Refer to page 19 for applicable couplings.

Permissible Overhang Length³

Horizontal Usage

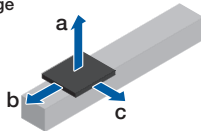

Wall-Mounted Usage

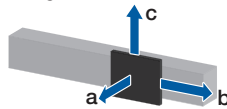

Vertical Usage

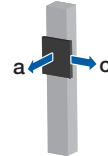

Hypothetical motor capacity 50 W	Ball screw lead (mm)	Load mass (kg)	a (mm)	b (mm)	c (mm)	
Direct coupling	A type	2	6.5	500	160	420
			13.5	500	70	200
			27.5	500	30	90
		6	6.5	500	160	370
			13.5	500	70	180
			27.5	240	30	80
	B type	2	9.5	500	500	500
			19	500	290	290
			38.5	500	130	140
		6	9.5	500	500	500
			19	500	290	280
			38.5	500	130	130

Hypothetical motor capacity 50 W	Ball screw lead (mm)	Load mass (kg)	a (mm)	b (mm)	c (mm)	
Direct coupling	A type	2	5.5	490	190	500
			11	220	80	500
			22	80	30	500
		6	5.5	440	190	500
			11	190	80	500
			22	70	30	260
	B type	2	7.5	500	500	500
			15.5	340	330	500
			31	140	140	500
		6	7.5	500	500	500
			15.5	330	330	500
			31	130	140	500

Hypothetical motor capacity 50 W	Ball screw lead (mm)	Load mass (kg)	a (mm)	c (mm)	
Direct coupling	A type	2	3.5	300	300
			7	130	130
			14	40	40
		6	1.5	500	500
			3.5	270	270
			7	110	110
	B type	2	3	500	500
			6.5	500	500
			13.5	400	400
		6	2	500	500
			4.5	500	500
			9.5	500	500

³ Value when LM Guide running life is restricted to 5,000 km (3,000 km for 2 mm lead only). The calculation conditions are as follows.

Stroke: 135 mm (A type), 95 mm (B type). Acceleration/deceleration rate: 0.3 G. Speed: 100 mm/s (for 2 mm lead), 300 mm/s (for 6 mm lead). Overhang direction: Load in one direction only. Dimensions a, b, and c are the dimensions from the center of the table upper surface.

Dimensions

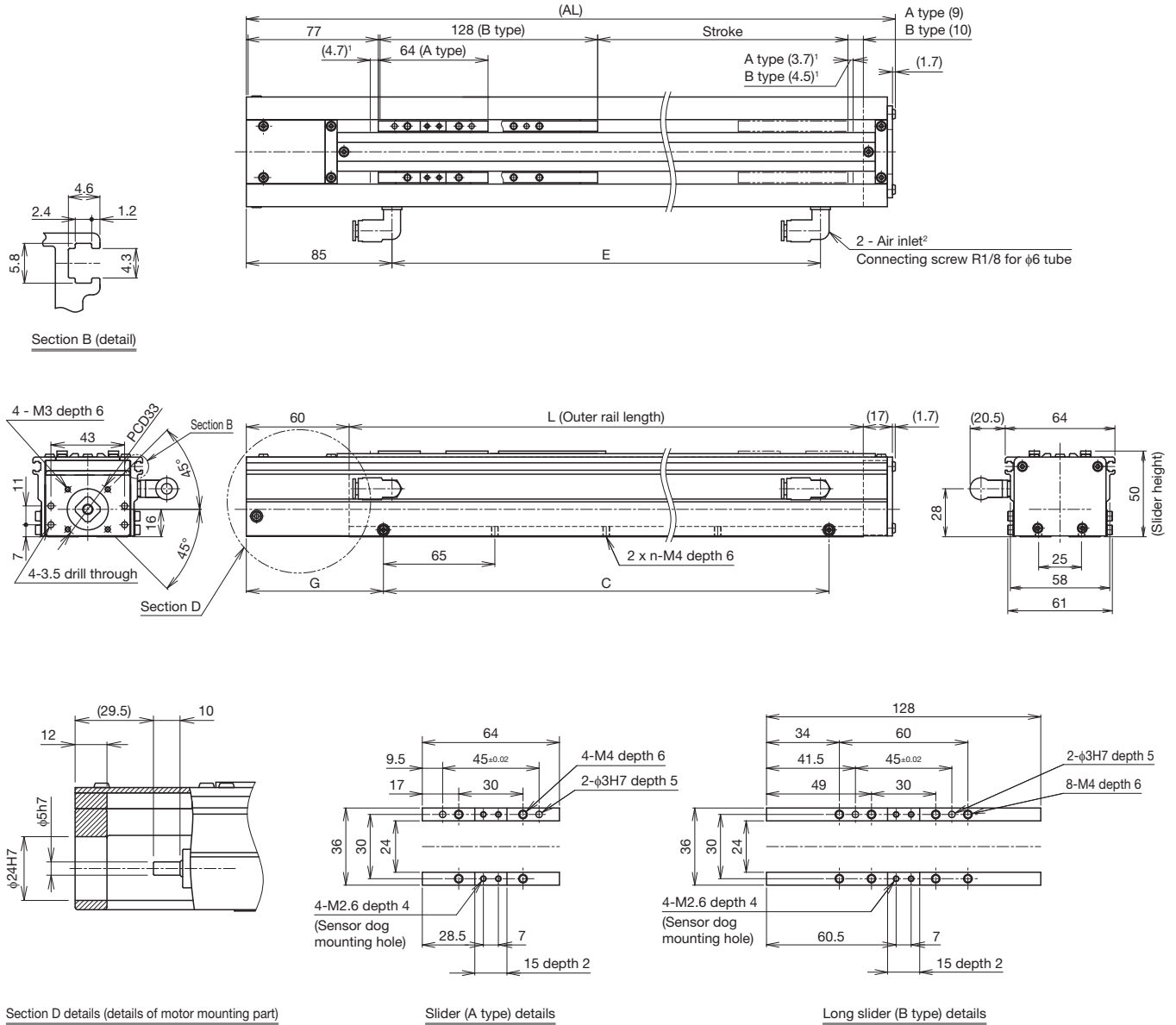

¹ Dimensions from the mechanical stopper to the stroke start position.
² Suction ports can be mounted from either side. Plug any unused suction ports. Two plugs are included.

Stroke (mm) (Stroke between mechanical stoppers)	A type	60 (68.4)	110 (118.4)	160 (168.4)	210 (218.4)
	B type	-	45 (54.2)	95 (104.2)	145 (154.2)
Maximum speed ³ (mm/s)	Ball screw lead: 2 mm	200			
	Ball screw lead: 6 mm	600			
Dimensions (mm)	AL	228.7	278.7	328.7	378.7
	L	150	200	250	300
	G	70	95	87.5	80
	C	130	130	195	260
E	100	150	200	250	
Mounting hole count	n	3	3	4	5
Weight ⁴ (kg)		1.8	2	2.3	2.5

³ Maximum speed is limited by the actuator's permissible speed.
⁴ The weight with a long slider (B type) has 0.47 kg added.

Options

Sensors

Optional photo sensors and proximity sensors are available. Keep the following precautions (Notes 1 to 5) in mind for use. Various sensors can be mounted using the T-slot in the side cover.

Symbol	Description	Model	Accessories
0	None	-	-
2	Photo sensor ¹ (x3)	EE-SX671 (OMRON Corporation)	Mounting screws, nuts, sensor dog (x1 or 2), mounting plates (x3), connectors (EE-1001 x3)
6	Photo sensor ¹ (x3)	EE-SX674 (OMRON Corporation)	Mounting screws, nuts, sensor dog (x1 or 2), mounting plates (x3), connectors (EE-1001 x3)
E	Proximity sensor NO contact ² (x1) NC contact ³ (x2)	APM-D3A1-001 (Azbil Corporation) APM-D3B1-003 (Azbil Corporation)	Mounting screws, nuts, sensor dog (x1 or 2)

¹ The photo sensors can be switched between ON when lit and ON when unlit.

² NO contact: Normally open contact point

³ NC contact: Normally closed contact point

- Note 1) The sensor accessories are supplied with the actuator unit. To be mounted by the customer.
- Note 2) If proximity sensors are placed too close to each other, they may not work properly. In this case, provide sensors with variant frequencies. (For specifications, contact each manufacturer.)
- Note 3) For a stroke less than 70 mm, 2 sensor dogs are included.
- Note 4) The sensor output is all NPN output.
- Note 5) Mounting of sensors other than those in the table above is possible. Contact THK for details.

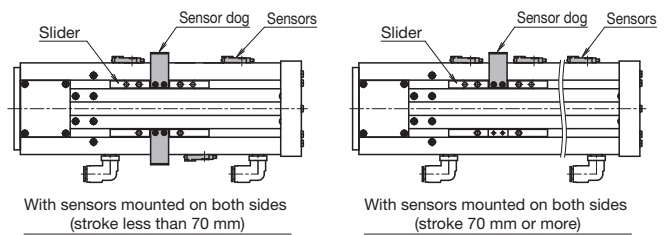
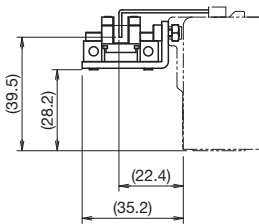
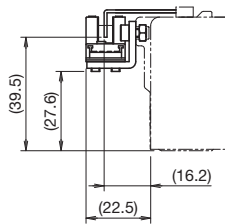

Photo Sensor Mounting Dimensions



Symbol	Model	Manufacturer
2	EE-SX671	OMRON Corporation

Sensor dog width: 14 mm



Symbol	Model	Manufacturer
6	EE-SX674	OMRON Corporation

Sensor dog width: 14 mm

Proximity Sensor Mounting Dimensions

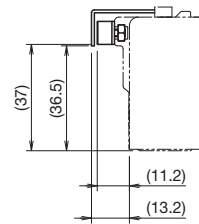

Symbol	Model	Manufacturer
E	APM-D3A1-001	Azbil Corporation
	APM-D3B1-003	

Sensor dog width: 14 mm

Base Plate

The height with the optional base plate mounted is the same as the conventional product (CKR).

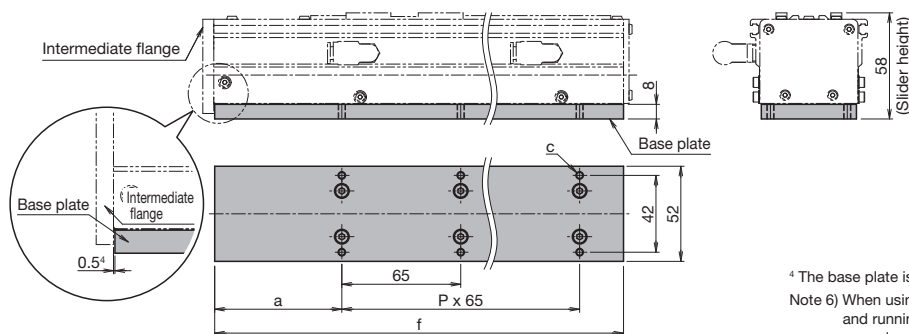

⁴ The base plate is 0.5 mm shorter than the end of the intermediate flange.
Note 6) When using the base plate, the accuracy grade positioning accuracy and running parallelism (vertical direction) are equivalent to the normal grade (no symbol).

Stroke ⁵ (mm)	a (mm)	P	c	f (mm)
60	69.5	2	6 x M4 Helisert 1.5 D	223.5
110	94.5			273.5
160	87	3	8 x M4 Helisert 1.5 D	323.5
210	79.5	4	10 x M4 Helisert 1.5 D	373.5

⁵ Stroke with a slider (A type).

Options

Intermediate Flange

Intermediate flanges are available to mount various kinds of motors.
Specify an intermediate flange that matches the motor used.

Compatibility Table: Motors used, intermediate flanges, and couplings

Motor type	Manufacturer	Series	Motor model	Motor rated output (W)	Flange angle	Intermediate flange	Applicable coupling model		
							Miki Pulley Co., Ltd.	Nabeya Bi-tech Kaisha (NBK)	
AC servo motor	Yaskawa Electric Corporation	Σ-V	SGMJV-A5	50	□40	A	SFC-010DA2-5B-8B-L32	XGT2-19C-5-8	
			SGMAV-A5						
		Σ-7	SGM7J-A5	50	□40	A			
			SGM7A-A5						
	Mitsubishi Electric Corporation	MELSERVO	J4	HG-KR053	50	□40			A
			JN	HG-MR053					
			JN	HF-KN053					
	Tamagawa Seiki Co., Ltd.	TBL-iii	TS4602	50	□40	A			
		TBL-iv	TSM3102						
	Panasonic Corporation	MINAS	A5	MSMD5A	50	□38			B
				MSME5A					
			A6	MSMF5A	50	□38			B
				MHMF5A					
	Keyence Corporation	SV	SV-M005	50	□40	A			
SV2		SV2-M005							
Sanyo Denki Co., Ltd.	SANMOTION R	R2□A04005	50	□40	A				
OMRON Corporation	OMNUC G5	R88M-K05030	50	□40	A				
Fanuc Corporation	β is Series	βis0.2/5000	50	□40	A				

Motor type	Manufacturer	Series	Motor model	Flange angle	Intermediate flange	Applicable coupling model		
						Miki Pulley Co., Ltd.	Nabeya Bi-tech Kaisha (NBK)	
Stepper motor	Oriental Motor Co. Ltd.	α step	AZ4*, AR4* (excluding AZM48)	□42	C	SFC-010DA2-5B-6B-L37	XGL2-15C-5-6	
			AZM48			SFC-010DA2-5B-8B-L32	XGT2-19C-5-8	
		5-phase	CRK			CRK54*	SFC-010DA2-5B-5B-L37	XGL2-15C-5-5
			RKII			RKS54*	SFC-010DA2-5B-6B-L37	XGL2-15C-5-6
			PKA			PKA544	SFC-010DA2-5B-5B-L37	XGL2-15C-5-5
			CVK			PKP54*	SFC-010DA2-5B-5B-L37	XGL2-15C-5-5
		2-phase	CVK			PKP24*	SFC-010DA2-5B-5B-L37	XGL2-15C-5-5
		Keyence Corporation	2-phase			QS-M42	□42	C
	Sanyo Denki Co., Ltd.	PB	PBDM423, PBA**423	□42	C	SFC-010DA2-5B-6B-L37	XGL2-15C-5-6	
		5-phase	FAF54*/FDF54*/FA511M42/FB511M42			SFC-010DA2-5B-6B-L37	XGL2-15C-5-6	
			DB14H52*			SFC-010DA2-5B-5B-L37	XGT2-15C-5-5	
2-phase		DU15H52*						

Note 1) Motor model number in the table shows the main part of the model number only. For details about models, please refer to the catalogs from each motor manufacturer.
 Note 2) If the maximum torque for motors exceeds the permissible input torque (see page 15), establish safety measures to limit torque.
 Note 3) When installing a motor other than the motor model numbers listed above, contact THK.

CSKR26
A

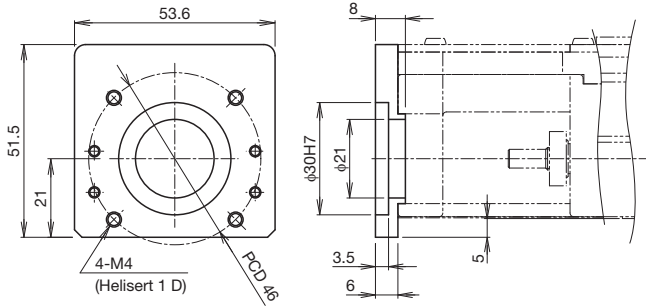

CSKR26
B

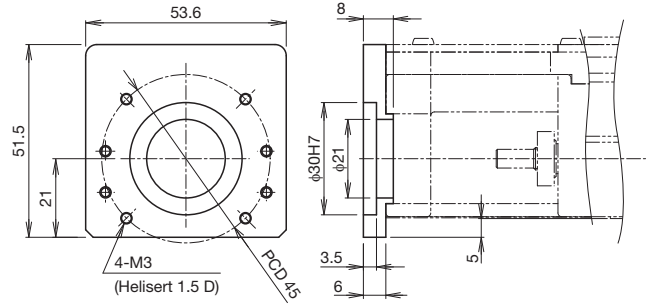

CSKR**	Actuator model
◇	◇: Intermediate flange

CSKR26
C

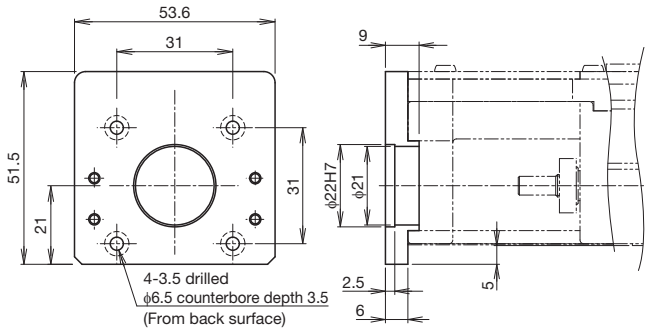

CSKR33

Main Unit Width 80.4 mm	Main Unit Height 61 mm	Stroke Max. 595 mm
-----------------------------------	----------------------------------	------------------------------

Model Configuration

Model (1)	Ball screw lead (2)	Slider type (3)	Stroke (4)	Accuracy grade (5)	With/without motor (6)	Sensors (7)	Intermediate flange (8)	Base plate (9)
CSKR33	06	A	0045	P	0	J	A	N
CSKR33	06: 6 mm	A: Slider	0045: 45 mm	No symbol: Normal grade	0: Direct coupling (without motor)	0	A	N: No base plate
	10: 10 mm	B: Long slider	to	H: High accuracy grade	1: Direct coupling (Specified motor prepared and mounted by THK)	2	C	B: With base plate
	20: 20 mm		0595: 595 mm	P: Precision grade	When selecting "0": A coupling is not provided. Indicate when placing an order if a coupling is required.	6	G	
					When selecting "1": The specified motor will be installed. Indicate the motor cable direction separately. Select (8) Intermediate flange to match the specified motor.	E	H	
						J	Intermediate flange details	

Sensor details → p. 24

(3) Slider type

A: Slider
(A type)



B: Long slider
(B type)



The interior uses 1 SKR block (A type).

The interior uses 2 SKR blocks (B type), extending the total slider length.

Selection Materials

Basic Specifications

LM Guide	Basic dynamic load rating C (N)		17000		
	Basic static load rating C ₀ (N)		20400		
	Radial clearance (mm)	Normal grade/High accuracy grade (H)	-0.004 to 0		
		Precision grade (P)	-0.012 to -0.004		
Geometrical moment of inertia	I _x ¹ (mm ⁴)	5.35 × 10 ⁴			
	I _y ² (mm ⁴)	3.52 × 10 ⁵			
	Weight (kg/m)	6.1			
Ball screw	Ball screw lead (mm)		6	10	20
	Basic dynamic load rating Ca (N)	Normal grade/High accuracy grade (H)	4400	2700	2620
		Precision grade (P)			
	Basic static load rating C _{0a} (N)	Normal grade/High accuracy grade (H)	6290	3780	3770
		Precision grade (P)			
	Screw shaft diameter (mm)		φ13		
	Thread minor diameter (mm)		φ10.8		
	Ball center-to-center diameter (mm)		φ13.5		
Permissible rotational speed ³ (min ⁻¹)	Normal grade/High accuracy grade (H)	6000			
	Precision grade (P)				
Bearing (Fixed side)	Axial direction	Basic dynamic load rating Ca (N)	6250		
		Static permissible load P _{0a} (N)	2700		
Permissible input torque (N·m)		2.8	3.2		
Static permissible moment ⁴ (N·m)		M _A : 173 (990), M _B : 173 (990), M _C : 214 (428)			
Running life ⁵ (km)		5,000	10,000		
Standard grease/Grease nipple used		THK AFE-CA Grease/PB107			
Guideline value of vacuum rate ⁶ × 10 ⁻³ (m ³ /min)		10 to 70			

¹ I_x = Geometrical moment of inertia of area around the X-axis.

² I_y = Geometrical moment of inertia of area around the Y-axis.

³ Permissible rotational speed may decrease if the stroke is lengthened.

⁴ The value in parentheses is with a long slider (B type).

⁵ The conditions for calculation are as follows:

Stroke: 395 mm (A type), 320 mm (B type). Speed: 300 mm/s (for 6 mm lead), 500 mm/s (for 10 mm lead), 1000 mm/s (for 20 mm lead). Load mass: maximum load capacity (see p. 7).

Acceleration and deceleration rate: acceleration and deceleration rate when maximum load capacity is set (see p. 7). Center of gravity: center of the table upper surface.

⁶ The vacuum rate does not include the effect of piping resistance.

Note 1) Customized products can also be made to handle special environments or large axial loads (25% or more of the basic dynamic load rating Ca). Consult with THK.

Note 2) LM Guide load rating is the load rating for the slider (A type).

Geometrical moment of inertia

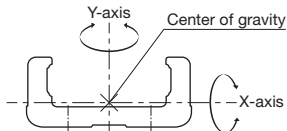

Static permissible moment

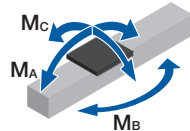

Accuracy

Accuracy grade	Item	Stroke ⁷					
		45	95	195	295	395	495
Normal grade (no symbol)	Positioning repeatability (mm)	±0.01					
	Positioning accuracy (mm)	Not specified					
	Running parallelism (vertical direction) (mm)	Not specified					
	Backlash (mm)	0.02					
	Starting torque (N·cm)	8.7					

Accuracy grade	Item	Stroke ⁷					
		45	95	195	295	395	495
High accuracy grade (H)	Positioning repeatability (mm)	±0.005					
	Positioning accuracy (mm)	0.06		0.1		0.12	
	Running parallelism (vertical direction) (mm)	0.025		0.035		0.04	
	Backlash (mm)	0.02					
	Starting torque (N·cm)	8.7					

Accuracy grade	Item	Stroke ⁷					
		45	95	195	295	395	495
Precision grade (P)	Positioning repeatability (mm)	±0.003					
	Positioning accuracy (mm)	0.02		0.025		0.03	
	Running parallelism (vertical direction) (mm)	0.01		0.015		0.02	
	Backlash (mm)	0.003					
	Starting torque (N·cm)	18.3					

⁷ Stroke with a slider (A type).

Note 3) Precision evaluation in accordance with THK standards.

Note 4) Measured using a motor for inspection.

Note 5) The starting torque represents the value when containing THK AFE-CA Grease.

Note 6) Contact THK for accuracy higher than the standard stroke.

Motor Selection Specifications

Stroke ¹ (mm)	Outer rail length (mm)	LM Guide		Ball screw		Motor mounting part
		Weight of moving element (kg)	Sliding resistance value ² (N)	Lead (mm)	Shaft length (mm)	Shaft end diameter (mm)
45 to 595	150 to 700	A type 0.68 B type 1.43	4.7	6, 10, 20	198 to 748	φ8h7

¹ Stroke with a slider (A type).

² Value with a slider (A type). This value is the sum of the rolling resistance value and seal resistance value.

Note) Refer to page 25 for applicable couplings.

Permissible Overhang Length³

Horizontal Usage

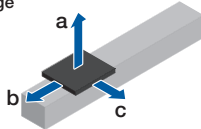

Wall-Mounted Usage

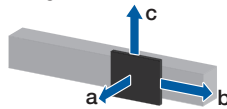

Vertical Usage

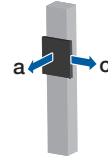

Hypothetical motor capacity 100 W	Ball screw lead (mm)	Load mass (kg)	a	b	c	
			(mm)	(mm)	(mm)	
Direct coupling	A	6	10.5	600	150	400
			21.5	600	70	190
			43.5	300	30	80
		10	8.5	600	190	460
			17	590	90	220
			34.5	260	40	100
	20	3	600	430	600	
		6	600	210	400	
		12.5	400	100	190	
	B	6	15	600	600	600
			30.5	600	300	290
			61.5	600	140	130
10		8.5	600	600	600	
		17	600	560	520	
		34	600	270	250	
20	2.5	600	600	600		
	5	600	600	600		
	10.5	600	600	600		

Hypothetical motor capacity 100 W	Ball screw lead (mm)	Load mass (kg)	a	b	c	
			(mm)	(mm)	(mm)	
Direct coupling	A	6	8.5	460	170	600
			17.5	190	70	600
			35	60	20	320
		10	7	500	210	600
			14.5	220	90	600
			29.5	80	30	260
	20	3	600	410	600	
		6	370	190	600	
		12.5	150	80	340	
	B	6	12	600	600	600
			24.5	330	340	600
			49	130	130	600
10		8.5	600	600	600	
		17	490	520	600	
		34	210	220	600	
20	2.5	600	600	600		
	5	600	600	600		
	10.5	600	600	600		

Hypothetical motor capacity 100 W	Ball screw lead (mm)	Load mass (kg)	a	c	
			(mm)	(mm)	
Direct coupling	A	6	4.5	320	320
			9.5	140	140
			19	50	50
		10	3	520	520
			6	240	240
			12	100	100
	20	1	600	600	
		2.5	420	420	
		5.5	190	190	
	B	6	5	600	600
			10.5	600	600
			21.5	420	420
10		3	600	600	
		6	600	600	
		12	600	600	
20	1	600	600		
	2	600	600		
	4.5	600	600		

³ Value when LM Guide running life is restricted to 10,000 km (5,000 km for 6 mm lead only). The calculation conditions are as follows.

Stroke: 320 mm (A type), 320 mm (B type). Acceleration/deceleration rate: 0.3 G. Speed: 300 mm/s (for 6 mm lead), 500 mm/s (for 10 mm lead), 1000 mm/s (for 20 mm lead). Overhang direction: Load in one direction only. Dimensions a, b, and c are the dimensions from the center of the table upper surface.

Dimensions

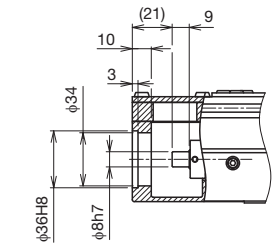
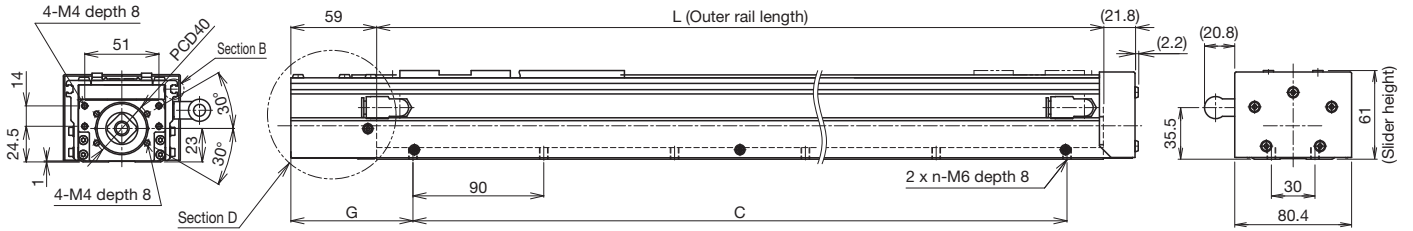
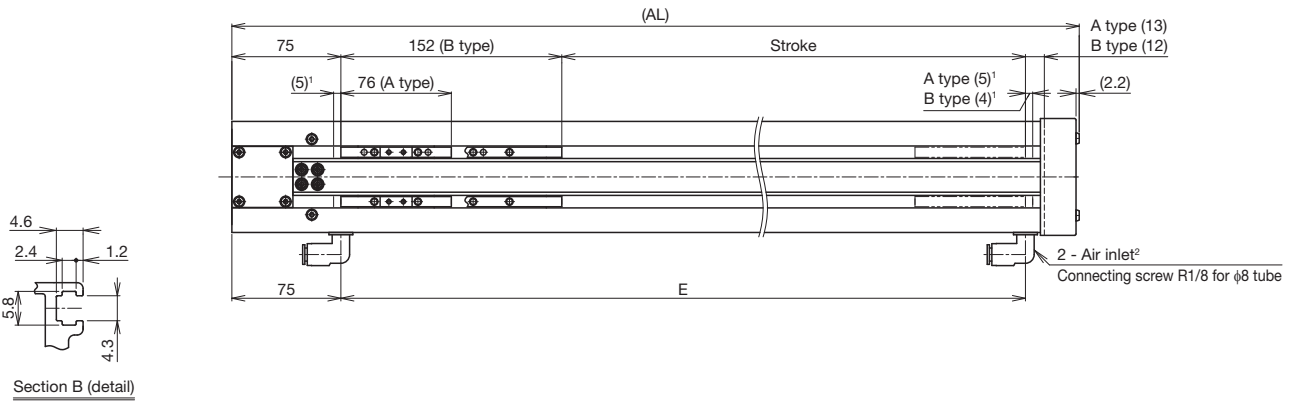

Section D details (details of motor mounting part)

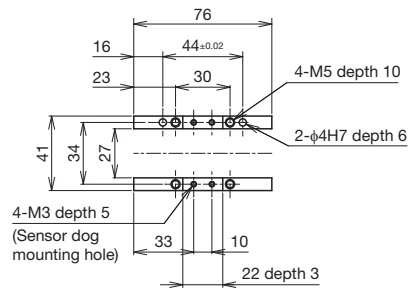

Slider (A type) details

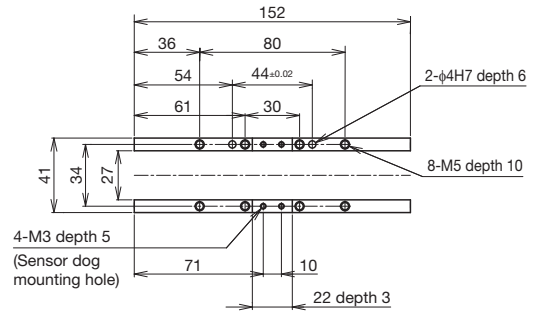

Long slider (B type) details

¹ Dimensions from the mechanical stopper to the stroke start position.
² Suction ports can be mounted from either side. Plug any unused suction ports. Two plugs are included.

Stroke (mm) (Stroke between mechanical stoppers)	A type	45 (55)	95 (105)	195 (205)	295 (305)	395 (405)	495 (505)	595 (605)
	B type	-	-	120 (129)	220 (229)	320 (329)	420 (429)	520 (529)
Maximum speed ³ (mm/s)	Ball screw lead: 6 mm	600						
	Ball screw lead: 10 mm	1000						
	Ball screw lead: 20 mm	2000						
Dimensions (mm)	AL	233	283	383	483	583	683	783
	L	150	200	300	400	500	600	700
	G	89	69	74	79	84	89	94
	C	90	180	270	360	450	540	630
	E	121	171	271	371	471	571	671
Mounting hole count	n	2	3	4	5	6	7	8
Weight ⁴ (kg)		3.2	3.7	4.5	5.4	6.2	7.2	8

³ Maximum speed is limited by the actuator's permissible speed.

⁴ The weight with a long slider (B type) has 0.75 kg added.

Options

Sensors

Optional photo sensors and proximity sensors are available. Keep the following precautions (Notes 1 to 5) in mind for use. Various sensors can be mounted using the T-slot in the side cover.

Symbol	Description	Model	Accessories
0	None	-	-
2	Photo sensor ¹ (x3)	EE-SX671 (OMRON Corporation)	Mounting screws, nuts, sensor dog (x1 or 2), mounting plates (x3), connectors (EE-1001 x3)
6	Photo sensor ¹ (x3)	EE-SX674 (OMRON Corporation)	Mounting screws, nuts, sensor dog (x1 or 2), mounting plates (x3), connectors (EE-1001 x3)
E	Proximity sensor NO contact ² (x1) NC contact ³ (x2)	APM-D3A1-001 (Azbil Corporation) APM-D3B1-003 (Azbil Corporation)	Mounting screws, nuts, sensor dog (x1 or 2)
J	Proximity sensor NO contact ² (x1) NC contact ³ (x2)	GX-F12A (Panasonic Industrial Devices SUNX Co., Ltd.) GX-F12B (Panasonic Industrial Devices SUNX Co., Ltd.)	Mounting screws, nuts, sensor dog (x1 or 2)

¹ The photo sensors can be switched between ON when lit and ON when unlit.
² NO contact: Normally open contact point
³ NC contact: Normally closed contact point

- Note 1) The sensor accessories are supplied with the actuator unit. To be mounted by the customer.
- Note 2) If proximity sensors are placed too close to each other, they may not work properly. In this case, provide sensors with variant frequencies. (For specifications, contact each manufacturer.)
- Note 3) For a stroke less than 70 mm, 2 sensor dogs are included.
- Note 4) The sensor output is all NPN output.
- Note 5) Mounting of sensors other than those in the table above is possible. Contact THK for details.

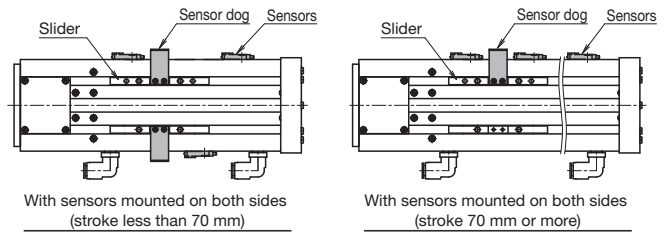
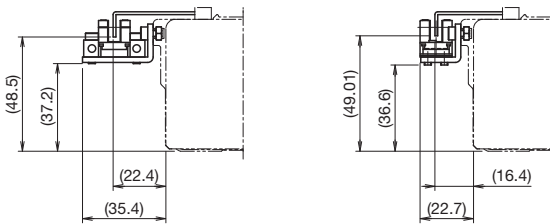

Photo Sensor Mounting Dimensions



Symbol	Model	Manufacturer	Symbol	Model	Manufacturer
2	EE-SX671	OMRON Corporation	6	EE-SX674	OMRON Corporation

Sensor dog width: 20 mm

Sensor dog width: 20 mm

Proximity Sensor Mounting Dimensions

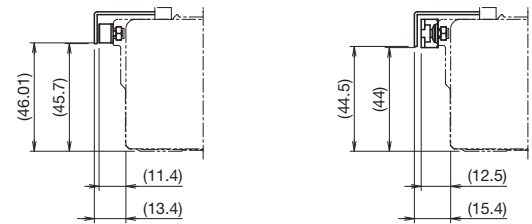

Symbol	Model	Manufacturer	Symbol	Model	Manufacturer
E	APM-D3A1-001 APM-D3B1-003	Azbil Corporation	J	GX-F12A GX-F12B	Panasonic Industrial Devices SUNX Co., Ltd.

Sensor dog width: 20 mm

Sensor dog width: 20 mm

Base Plate

The height with the optional base plate mounted is the same as the conventional product (CKR).

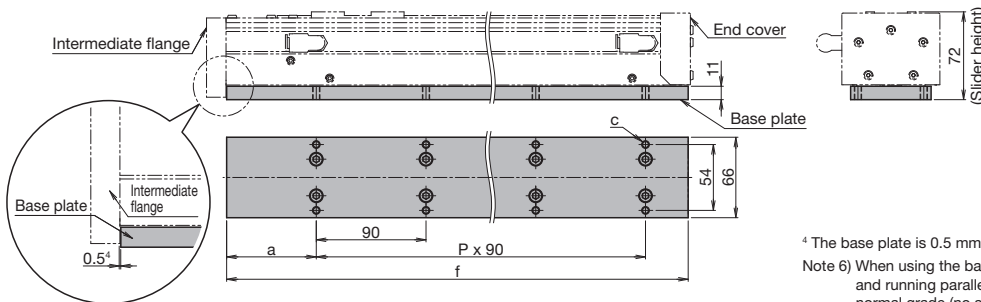

⁴ The base plate is 0.5 mm shorter than the end of the intermediate flange.
 Note 6) When using the base plate, the accuracy grade positioning accuracy and running parallelism (vertical direction) are equivalent to the normal grade (no symbol).

Stroke ⁵ (mm)	a (mm)	P	c	f (mm)
45	88.5	1	4 x M6 Helisert 1.5 D	228.5
95	68.5	2	6 x M6 Helisert 1.5 D	278.5
195	73.5	3	8 x M6 Helisert 1.5 D	378.5
295	78.5	4	10 x M6 Helisert 1.5 D	478.5
395	83.5	5	12 x M6 Helisert 1.5 D	578.5
495	88.5	6	14 x M6 Helisert 1.5 D	678.5
595	93.5	7	16 x M6 Helisert 1.5 D	778.5

⁵ Stroke with a slider (A type).

Options

Intermediate Flange

Intermediate flanges are available to mount various kinds of motors.
Specify an intermediate flange that matches the motor used.

Compatibility Table: Motors used, intermediate flanges, and couplings

Motor type	Manufacturer	Series	Motor model	Motor rated output (W)	Flange angle	Intermediate flange	Applicable coupling model						
							Miki Pulley Co., Ltd.	Nabeya Bi-tech Kaisha (NBK)					
AC servo motor	Yaskawa Electric Corporation	Σ-V	SGMJV-A5	50	□40	A	SFC-020DA2-8B-8B	XGT2-19C-8-8					
			SGMAV-A5										
			SGMJV-01	100									
			SGMAV-01										
		SGMJV-C2	150										
		SGM7J-A5		Σ-7					□40	A	SFC-020DA2-8B-8B	XGT2-19C-8-8	
		SGM7A-A5											
		SGMJV-01											
	SGM7A-01												
	SGMJV-C2												
	SGM7J-C2												
	Mitsubishi Electric Corporation	MELSERVO	J4	HG-KR053	50	□40	A	SFC-020DA2-8B-8B	XGT2-19C-8-8				
				HG-MR053									
				HG-KR13	100								
			HG-MR13										
			JN	HF-KN053	50					□40	A	SFC-020DA2-8B-8B	XGT2-19C-8-8
				HF-KN13									
	Tamagawa Seiki Co., Ltd.	TBL-III	TS4602	50	□40	A	SFC-020DA2-8B-8B	XGT2-19C-8-8					
			TS4603	100									
			TS4604	150									
		TBL-IV	TSM3102	50					□40	A	SFC-020DA2-8B-8B	XGT2-19C-8-8	
			TSM3104	100									
	Panasonic Corporation	MINAS	A5	MSMD5A	50	□38	C	SFC-020DA2-8B-8B	XGT2-19C-8-8				
MSME5A													
MSMD01				100									
MSME01													
A6		MHMF5A	50	□38	C					SFC-020DA2-8B-8B	XGT2-19C-8-8		
		MHMF01		□40	A					SFC-020DA2-8B-8B	XGT2-19C-8-8		
		MHMF01	100	□38	C					SFC-020DA2-8B-8B	XGT2-19C-8-8		
		MHMF01		□40	A					SFC-020DA2-8B-8B	XGT2-19C-8-8		
Keyence Corporation	SV	SV-M005	50	□40	A	SFC-020DA2-8B-8B	XGT2-19C-8-8						
		SV-M010	100										
	SV2	SV2-M005	50										
		SV2-M010	100										
Sanyo Denki Co., Ltd.	SANMOTION R	R2□A04005	50	□40	A	SFC-020DA2-8B-8B	XGT2-19C-8-8						
		R2EA04008	80										
		R2□A04010	100										
OMRON Corporation	OMNUC G5	R88M-K05030	50	□40	A	SFC-020DA2-8B-8B	XGT2-19C-8-8						
		R88M-K10030	100										
	1S	R88M-1M10030	100					□40	A	SFC-020DA2-8B-8B	XGT2-19C-8-8		
Fanuc Corporation	β is Series	βis0.2/5000	50	□40	A	SFC-010DA2-8B-8B	XGT2-19C-8-8						
		βis0.3/5000	100										

Motor type	Manufacturer	Series	Motor model	Flange angle	Intermediate flange	Applicable coupling model		
						Miki Pulley Co., Ltd.	Nabeya Bi-tech Kaisha (NBK)	
Stepper motor	Oriental Motor Co. Ltd.	α step	AZ4*, AR4* (excluding AZM48)	□42	G	SFC-010DA2-6B-8B-L29	XGT2-19C-6-8	
			AZM48	□42	G	SFC-010DA2-6B-8B-L29	XGT2-19C-8-8	
			AZ6*, AR6*	□60	H	SFC-020DA2-8B-10B	XGT2-25C-8-10	
			CRK54*	□42	G	SFC-010DA2-5B-8B-L29	XGT2-19C-5-8	
		5-phase	CRK'	CRK56* (CRK569PM*)	□60	H	SFC-020DA2-8B-8B (SFC-020DA2-8B-10B)	XGT2-25C-8-8 (XGT2-25C-8-10)
				RKS54*	□42	G	SFC-010DA2-6B-8B-L29	XGT2-19C-6-8
			RK II	RKS56*	□60	H	SFC-020DA2-8B-10B	XGT2-25C-8-10
				PKA544	□42	G	SFC-010DA2-5B-8B-L29	XGT2-19C-5-8
			PKA	PKA566	□60	H	SFC-020DA2-8B-8B	XGT2-19C-8-8
				PKP54*	□42	G	SFC-010DA2-5B-8B-L29	XGT2-19C-5-8
		2-phase	CVK'	PKP56* (PKP569FM*)	□60	H	SFC-020DA2-8B-8B (SFC-020DA2-8B-10B)	XGT2-25C-8-8 (XGT2-25C-8-10)
				CVK24*	□42	G	SFC-010DA2-5B-8B-L29	XGT2-19C-5-8
		Keyence Corporation	2-phase	QS-M42	□42	G	SFC-010DA2-5B-8B-L29	XGT2-19C-5-8
				QS-M60	□60	H	SFC-020DA2-8B-8B	XGT2-25C-8-8
	Sanyo Denki Co., Ltd.	PB	PBDM423, PBA**423	□42	G	SFC-010DA2-6B-8B-L29	XGT2-19C-6-8	
			PBDM60*, PBA**60*	□60	H	SFC-020DA2-8B-10B	XGT2-25C-8-10	
		5-phase	FAF54*/FDF54*/FA511M42/FB511M42	□42	G	SFC-010DA2-6B-8B-L29	XGT2-19C-6-8	
			FAM56*/FDM56*/FA512M60/FB512M60	□60	H	SFC-020DA2-8B-10B	XGT2-25C-8-10	
			DB14H52*	□42	G	SFC-010DA2-5B-8B-L29	XGT2-19C-5-8	
		DU15H52*						
2-phase		DB16H78*	□60	H	SFC-020DA2-8B-8B	XGT2-25C-8-8		

¹ Items in parentheses have different motor shaft diameters and require a coupling to be specified.
 Note 1) Motor model number in the table shows the main part of the model number only. For details about models, please refer to the catalogs from each motor manufacturer.
 Note 2) If the maximum torque for motors exceeds the permissible input torque (see page 21), establish safety measures to limit torque.
 Note 3) When installing a motor other than the motor model numbers listed above, contact THK.

CSKR33
A

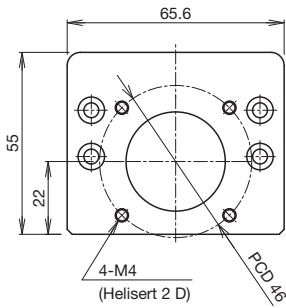

CSKR33
C

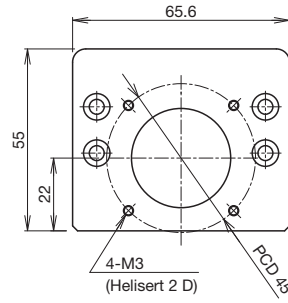

CSKR**	Actuator model
◇	◇: Intermediate flange

CSKR33
G

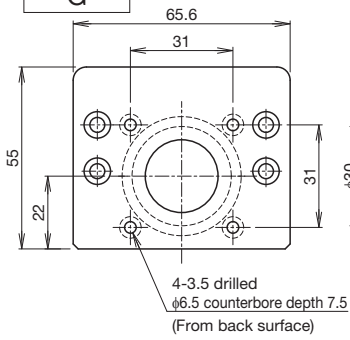

CSKR33
H

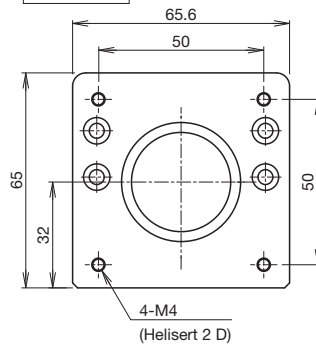

CSKR46

Main Unit Width 106 mm	Main Unit Height 77 mm	Stroke Max. 790 mm
----------------------------------	----------------------------------	------------------------------

Model Configuration

Model (1)	Ball screw lead (2)	Slider type (3)	Stroke (4)	Accuracy grade (5)	With/without motor (6)	Sensors (7)	Intermediate flange (8)	Base plate (9)
CSKR46	10	A	0190	P	0	J	B	N
CSKR46	10: 10 mm 20: 20 mm	A: Slider B: Long slider	0080: 80 mm to 0790: 790 mm	No symbol: Normal grade H: High accuracy grade P: Precision grade	0: Direct coupling (without motor) 1: Direct coupling (Specified motor prepared and mounted by THK) When selecting "0": A coupling is not provided. Indicate when placing an order if a coupling is required. When selecting "1": The specified motor will be installed. Indicate the motor cable direction separately. Select (8) Intermediate flange to match the specified motor.	0 2 6 E J	B E I J	N: No base plate B: With base plate

Sensor details → p. 31
→ p. 30

(3) Slider type

A: Slider
(A type)



The interior uses 1 SKR block (A type).

B: Long slider
(B type)



The interior uses 2 SKR blocks (B type), extending the total slider length.

Selection Materials

Basic Specifications

LM Guide	Basic dynamic load rating C (N)		39500
	Basic static load rating C ₀ (N)		45900
	Radial clearance (mm)	Normal grade/High accuracy grade (H)	-0.006 to 0
		Precision grade (P)	-0.016 to -0.006
Geometrical moment of inertia	I _x ¹ (mm ⁴)	2.05 × 10 ⁵	
	I _y ² (mm ⁴)	1.45 × 10 ⁶	
	Weight (kg/m)		12.6
	Ball screw lead (mm)		10 20
Ball screw	Basic dynamic load rating Ca (N)	Normal grade/High accuracy grade (H)	4350 4240
		Precision grade (P)	
	Basic static load rating C _{0a} (N)	Normal grade/High accuracy grade (H)	6990 7040
		Precision grade (P)	
	Screw shaft diameter (mm)		φ15
	Thread minor diameter (mm)		φ12.5
Ball center-to-center diameter (mm)		φ15.75	
Permissible rotational speed ³ (min ⁻¹)	Normal grade/High accuracy grade (H)	6000	
	Precision grade (P)		
Bearing (Fixed side)	Axial direction	Basic dynamic load rating Ca (N)	6700
		Static permissible load P _{0a} (N)	3330
Permissible input torque (N·m)		5.3	
Static permissible moment ⁴ (N·m)		M _A : 579 (2852), M _B : 579 (2852), M _C : 382 (763)	
Running life ⁵ (km)		10,000	
Standard grease/Grease nipple used		THK AFE-CA Grease/A-M6F	
Guideline value of vacuum rate ⁶ × 10 ⁻³ (m ³ /min)		16 to 86	

¹ I_x = Geometrical moment of inertia of area around the X-axis.

² I_y = Geometrical moment of inertia of area around the Y-axis.

³ Permissible rotational speed may decrease if the stroke is lengthened.

⁴ The value in parentheses is with a long slider (B type).

⁵ The conditions for calculation are as follows:

Stroke: 490 mm (A type), 380 mm (B type). Speed: 500 mm/s (for 10 mm lead), 1000 mm/s (for 20 mm lead). Load mass: maximum load capacity (see p. 7). Acceleration and deceleration rate: acceleration and deceleration rate when maximum load capacity is set (see p. 7). Center of gravity: center of the table upper surface.

⁶ The vacuum rate does not include the effect of piping resistance.

Note 1) Customized products can also be made to handle special environments or large axial loads (25% or more of the basic dynamic load rating Ca). Consult with THK.

Note 2) LM Guide load rating is the load rating for the slider (A type).

Accuracy

Accuracy grade	Item	Stroke ⁷					
		190	290	390	490	590	690
Normal grade (no symbol)	Positioning repeatability (mm)	±0.01					
	Positioning accuracy (mm)	Not specified					
	Running parallelism (vertical direction) (mm)	Not specified					
	Backlash (mm)	0.02					
	Starting torque (N·cm)	12.3					

Accuracy grade	Item	Stroke ⁷					
		190	290	390	490	590	690
High accuracy grade (H)	Positioning repeatability (mm)	±0.005					
	Positioning accuracy (mm)	0.1			0.12	0.15	
	Running parallelism (vertical direction) (mm)	0.035			0.04	0.05	
	Backlash (mm)	0.02					
	Starting torque (N·cm)	12.3					

Accuracy grade	Item	Stroke ⁷					
		190	290	390	490	590	690
Precision grade (P)	Positioning repeatability (mm)	±0.003					
	Positioning accuracy (mm)	0.025			0.03		
	Running parallelism (vertical direction) (mm)	0.015			0.02		
	Backlash (mm)	0.003					
	Starting torque (N·cm)	18.3			20.7		

⁷ Stroke with a slider (A type).

Note 3) Precision evaluation in accordance with THK standards.

Note 4) Measured using a motor for inspection.

Note 5) The starting torque represents the value when containing THK AFE-CA Grease.

Note 6) Contact THK for accuracy higher than the standard stroke.

Geometrical moment of inertia

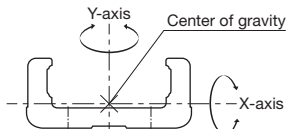

Static permissible moment

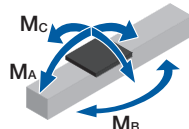

Motor Selection Specifications

Stroke ¹ (mm)	Outer rail length (mm)	LM Guide		Ball screw		Motor mounting part
		Weight of moving element (kg)	Sliding resistance value ² (N)	Lead (mm)	Shaft length (mm)	Shaft end diameter (mm)
190 to 790	340 to 940	A type 1.8 B type 3.77	8.1	10, 20	405 to 1005	φ10h7

¹ Stroke with a slider (A type).

² Value with a slider (A type). This value is the sum of the rolling resistance value and seal resistance value.

Note) Refer to page 31 for applicable couplings.

Permissible Overhang Length³

Horizontal Usage

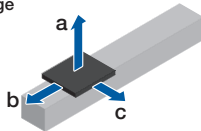

Wall-Mounted Usage

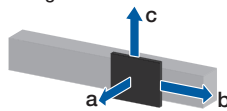

Vertical Usage

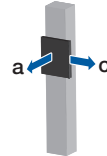

Hypothetical motor capacity 200 W		Ball screw lead (mm)	Load mass (kg)	a (mm)	b (mm)	c (mm)
Direct coupling	A type	10	19	860	300	740
			38.5	860	140	360
			77	500	60	160
		20	5.5	860	800	860
			11.5	860	390	790
	B type	10	23.5	860	190	390
			26	860	860	860
			52.5	860	610	570
		20	105	860	290	270
			4.5	860	860	860
		9	860	860	860	
		18.5	860	860	860	

Hypothetical motor capacity 200 W		Ball screw lead (mm)	Load mass (kg)	a (mm)	b (mm)	c (mm)
Direct coupling	A type	10	19	690	280	860
			38.5	310	120	860
			77	110	40	430
		20	5.5	860	780	860
			11.5	760	370	860
	B type	10	23.5	340	170	820
			26	860	860	860
			52.5	530	550	860
		20	105	230	230	860
			4.5	860	860	860
		9	860	860	860	
		18.5	860	860	860	

Hypothetical motor capacity 200 W		Ball screw lead (mm)	Load mass (kg)	a (mm)	c (mm)
Direct coupling	A type	10	4.5	860	860
			9	600	600
			18	280	280
		20	2	860	860
			4	860	860
	B type	10	8	510	510
			5.5	860	860
			11	860	860
		20	22.5	860	860
			1.5	860	860
		3.5	860	860	
		7.5	860	860	

Hypothetical motor capacity 400 W		Ball screw lead (mm)	Load mass (kg)	a (mm)	b (mm)	c (mm)
Direct coupling	A type	10	24	860	240	590
			48	860	110	280
			96	390	50	130
		20	13.5	860	330	670
			27.5	740	160	330
	B type	10	55	330	70	150
			34	860	860	860
			68	860	460	440
		20	136	860	210	200
			11.5	860	860	860
		23	860	860	860	
		46.5	860	550	470	

Hypothetical motor capacity 400 W		Ball screw lead (mm)	Load mass (kg)	a (mm)	b (mm)	c (mm)
Direct coupling	A type	10	19	690	280	860
			38.5	310	120	860
			77	110	40	430
		20	11.5	750	370	860
			23.5	340	170	810
	B type	10	47.5	130	70	330
			27	860	860	860
			54	510	530	860
		20	108.5	220	220	860
			11.5	860	860	860
		23	860	860	860	
		46.5	450	490	860	

Hypothetical motor capacity 400 W		Ball screw lead (mm)	Load mass (kg)	a (mm)	c (mm)
Direct coupling	A type	10	5.5	860	860
			11.5	460	460
			23	210	210
		20	4.5	860	860
			9	450	450
	B type	10	18	200	200
			8	860	860
			16	860	860
		20	32	860	860
			4.5	860	860
		9.5	860	860	
		19.5	860	860	

³ Value when LM Guide running life is restricted to 10,000 km. The calculation conditions are as follows.

Stroke: 490 mm (A type), 380 mm (B type). Acceleration/deceleration rate: 0.3 G. Speed: 500 mm/s (for 10 mm lead), 1000 mm/s (for 20 mm lead). Overhang direction: Load in one direction only. Dimensions a, b, and c are the dimensions from the center of the table upper surface.

Dimensions

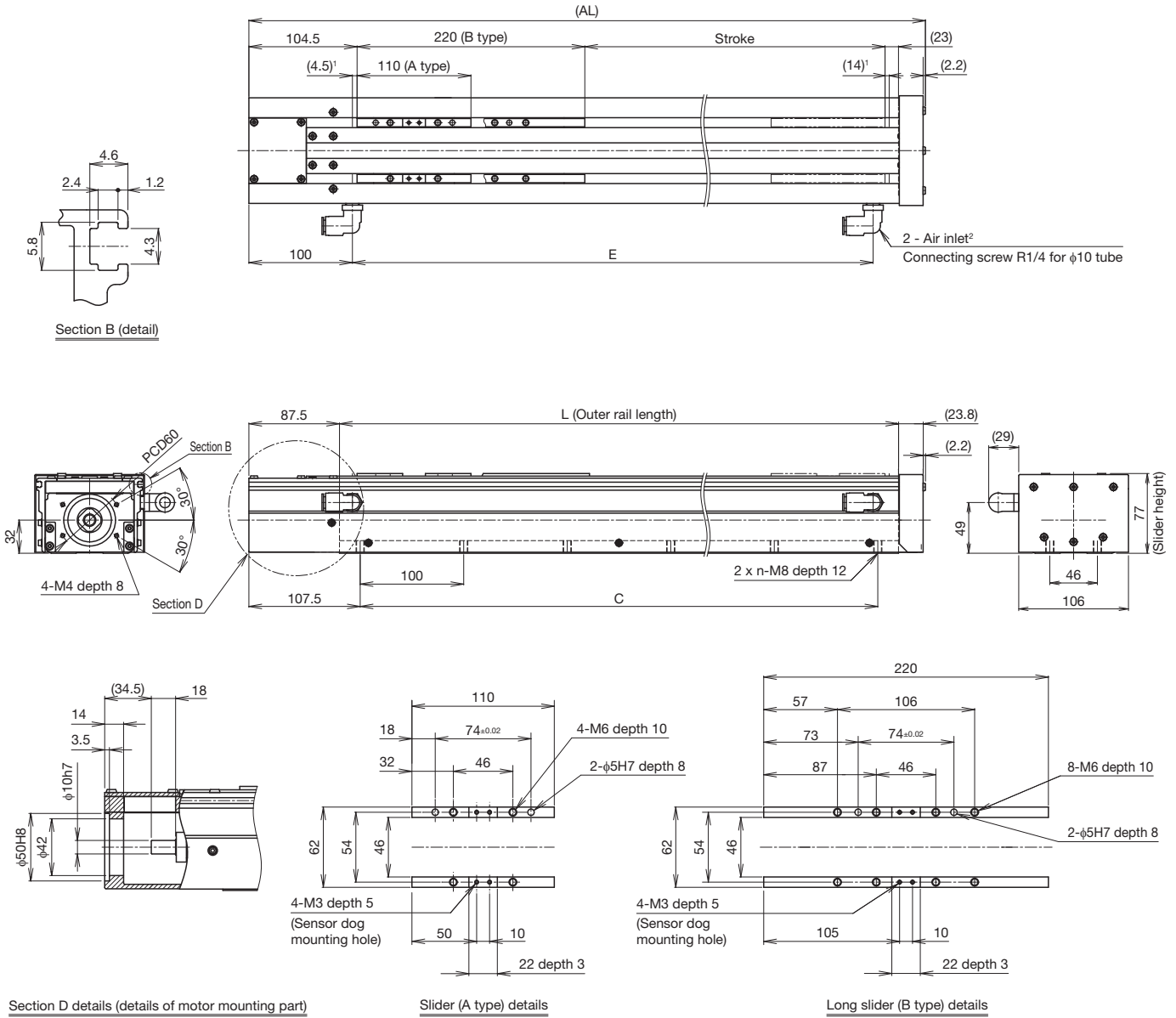

¹ Dimensions from the mechanical stopper to the stroke start position.
² Suction ports can be mounted from either side. Plug any unused suction ports. Two plugs are included.

Stroke (mm) (Stroke between mechanical stoppers)	A type	190 (208.5)	290 (308.5)	390 (408.5)	490 (508.5)	590 (608.5)	690 (708.5)	790 (808.5)
	B type	80 (98.5)	180 (198.5)	280 (298.5)	380 (398.5)	480 (498.5)	580 (598.5)	680 (698.5)
Maximum speed ³ (mm/s)	Ball screw lead: 10 mm	1000				730	550	430
	Ball screw lead: 20 mm	2000				1980	1430	840
Dimensions (mm)	AL	453.5	553.5	653.5	753.5	853.5	953.5	1053.5
	L	340	440	540	640	740	840	940
	C	300	400	500	600	700	800	900
	E	303	403	503	603	703	803	903
Mounting hole count	n	4	5	6	7	8	9	10
Weight ⁴ (kg)		9.6	11.2	12.8	14.4	16	17.6	19.2

³ Maximum speed is limited by the actuator's permissible speed.

⁴ The weight with a long slider (B type) has 1.97 kg added.

Options

Sensors

Optional photo sensors and proximity sensors are available. Keep the following precautions (Notes 1 to 5) in mind for use. Various sensors can be mounted using the T-slot in the side cover.

Symbol	Description	Model	Accessories
0	None	-	-
2	Photo sensor ¹ (x3)	EE-SX671 (OMRON Corporation)	Mounting screws, nuts, sensor dog (x1 or 2), mounting plates (x3), connectors (EE-1001 x3)
6	Photo sensor ¹ (x3)	EE-SX674 (OMRON Corporation)	Mounting screws, nuts, sensor dog (x1 or 2), mounting plates (x3), connectors (EE-1001 x3)
E	Proximity sensor NO contact ² (x1) NC contact ³ (x2)	APM-D3A1-001 (Azbil Corporation) APM-D3B1-003 (Azbil Corporation)	Mounting screws, nuts, sensor dog (x1 or 2)
J	Proximity sensor NO contact ² (x1) NC contact ³ (x2)	GX-F12A (Panasonic Industrial Devices SUNX Co., Ltd.) GX-F12B (Panasonic Industrial Devices SUNX Co., Ltd.)	Mounting screws, nuts, sensor dog (x1 or 2)

¹ The photo sensors can be switched between ON when lit and ON when unlit.
² NO contact: Normally open contact point
³ NC contact: Normally closed contact point

- Note 1) The sensor accessories are supplied with the actuator unit. To be mounted by the customer.
- Note 2) If proximity sensors are placed too close to each other, they may not work properly. In this case, provide sensors with variant frequencies. (For specifications, contact each manufacturer.)
- Note 3) For a stroke less than 70 mm, 2 sensor dogs are included.
- Note 4) The sensor output is all NPN output.
- Note 5) Mounting of sensors other than those in the table above is possible. Contact THK for details.

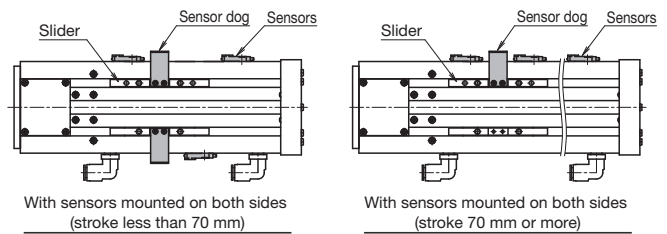
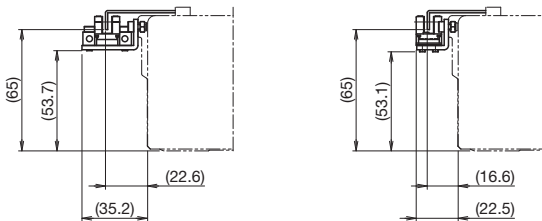

Photo Sensor Mounting Dimensions



Symbol	Model	Manufacturer
2	EE-SX671	OMRON Corporation

Sensor dog width: 20 mm

Symbol	Model	Manufacturer
6	EE-SX674	OMRON Corporation

Sensor dog width: 20 mm

Proximity Sensor Mounting Dimensions

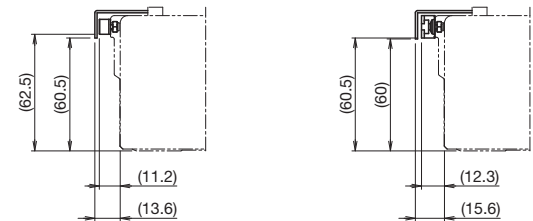

Symbol	Model	Manufacturer
E	APM-D3A1-001	Azbil Corporation
	APM-D3B1-003	

Sensor dog width: 20 mm

Symbol	Model	Manufacturer
J	GX-F12A	Panasonic Industrial Devices SUNX Co., Ltd.
	GX-F12B	

Sensor dog width: 20 mm

Base Plate

The height with the optional base plate mounted is the same as the conventional product (CKR).

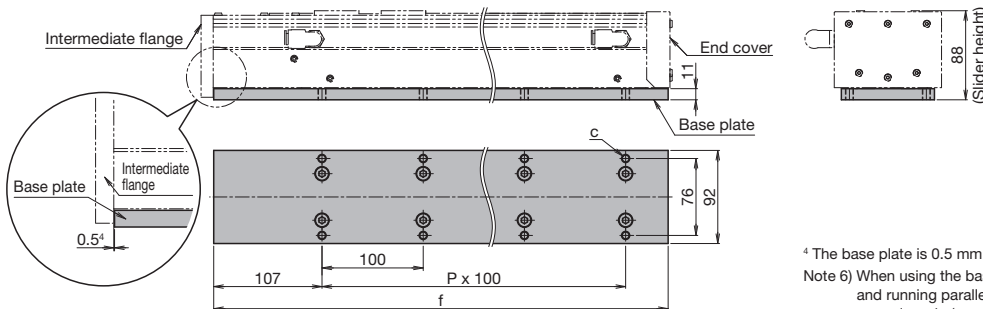

⁴ The base plate is 0.5 mm shorter than the end of the intermediate flange.
 Note 6) When using the base plate, the accuracy grade positioning accuracy and running parallelism (vertical direction) are equivalent to the normal grade (no symbol).

Stroke ⁵ (mm)	P	c	f (mm)
190	3	8 x M8 Helisert 1.5 D	449
290	4	10 x M8 Helisert 1.5 D	549
390	5	12 x M8 Helisert 1.5 D	649
490	6	14 x M8 Helisert 1.5 D	749
590	7	16 x M8 Helisert 1.5 D	849
690	8	18 x M8 Helisert 1.5 D	949
790	9	20 x M8 Helisert 1.5 D	1049

⁵ Stroke with a slider (A type).

Options

Intermediate Flange

Intermediate flanges are available to mount various kinds of motors.
Specify an intermediate flange that matches the motor used.

Compatibility Table: Motors used, intermediate flanges, and couplings

Motor type	Manufacturer	Series	Motor model	Motor rated output (W)	Flange angle	Intermediate flange	Applicable coupling model		
							Miki Pulley Co., Ltd.	Nabeya Bi-tech Kaisha (NBK)	
AC servo motor	Yaskawa Electric Corporation	Σ-V	SGMJV-02	200	□60	B	SFC-030DA2-10B-14B	XGT2-27C-10-14	
			SGMAV-02						
			SGMJV-04						
			SGMAV-04						
		SGMJV-06	400						
		SGM7J-02		200					
		SGM7A-02							
		SGM7J-04							
	SGM7A-04	400							
	SGM7J-06								
	SGM7A-06								
	SGM7J-06								
	Mitsubishi Electric Corporation	MELSERVO	J4	HG-KR23	200	□60	B	SFC-030DA2-10B-14B	XGT2-27C-10-14
				HG-MR23					
				HG-KR43					
			HG-MR43	400					
			HF-KN23		200				
			HF-KN43						
	HF-KN43	400							
	Tamagawa Seiki Co., Ltd.		TBL-III	TS4607	200	□60	B	SFC-030DA2-10B-14B	XGT2-27C-10-14
				TS4609					
		TSM3202							
		TSM3204	400						
		TSM3202							
TSM3204									
Panasonic Corporation	MINAS	A5	MSMD02	200	□60	E	SFC-030DA2-10B-11B	XGT2-30C-10-11	
			MSME02						
			MSMD04						
			MSME04						
	A6	MSMF02	200						
		MHMF02							
		MSMF04		400					
		MHMF04							
Keyence Corporation	SV	SV-M020	200		□60	B	SFC-030DA2-10B-14B	XGT2-27C-10-14	
		SV-M040							
	SV2	SV2-M020	200						
		SV2-M040		400					
Sanyo Denki Co., Ltd.	SANMOTION R	R2□A06020	200		□60	B	SFC-030DA2-10B-14B	XGT2-27C-10-14	
		R2AA06040		400					
OMRON Corporation	OMNUC G5	R88M-K20030	200		□60	E	SFC-030DA2-10B-11B	XGT2-30C-10-11	
		R88M-K40030		400					
	1S	R88M-1M20030	200						
		R88M-1M40030		400					

Motor type	Manufacturer	Series	Motor model	Flange angle	Intermediate flange	Applicable coupling model		
						Miki Pulley Co., Ltd.	Nabeya Bi-tech Kaisha (NBK)	
Stepper motor	Oriental Motor Co. Ltd.	α step	AZ6*, AR6*	□60	I	SFC-025DA2-10B-10B-L46	XGT2-25C-10-10	
			AZ9*, AR9*	□85	J	SFC-035DA2-10B-14B	XGT2-34C-10-14	
		5-phase	CRK ¹	CRK56* (CRK569PM*)	□60	I	SFC-025DA2-8B-10B-L46 (SFC-025DA2-10B-10B-L46)	XGL2-25C-8-10 (XGL2-25C-10-10)
			RK II	RKS56*	□60	I	SFC-025DA2-10B-10B-L46	XGL2-25C-10-10
			PKA	PKA566	□60	I	SFC-025DA2-8B-10B-L46	XGL2-25C-8-10
			CVK ¹	PKP56* (PKP569FM*)	□60	I	SFC-025DA2-8B-10B-L46 (SFC-025DA2-10B-10B-L46)	XGL2-25C-8-10 (XGL2-25C-10-10)
	Keyence Corporation	2-phase	QS-M60	□60	I	SFC-025DA2-8B-10B-L46	XGL2-25C-8-10	
	Sanyo Denki Co., Ltd.	PB	PBDM60*, PBA**60*	□60	I	SFC-025DA2-10B-10B-L46	XGL2-25C-10-10	
		5-phase	FAM56*/FDM56*/FA512M60/FB512M60					
		2-phase	DB16H78*					SFC-025DA2-8B-10B-L46

¹ Items in parentheses have different motor shaft diameters and require a coupling to be specified.
 Note 1) Motor model number in the table shows the main part of the model number only. For details about models, please refer to the catalogs from each motor manufacturer.
 Note 2) If the maximum torque for motors exceeds the permissible input torque (see page 27), establish safety measures to limit torque.
 Note 3) When installing a motor other than the motor model numbers listed above, contact THK.

CSKR46
B

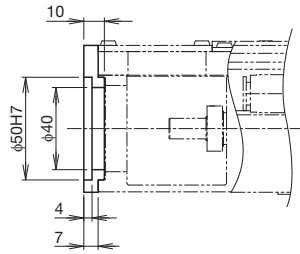
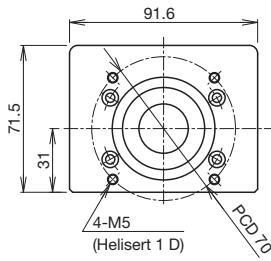

CSKR46
E

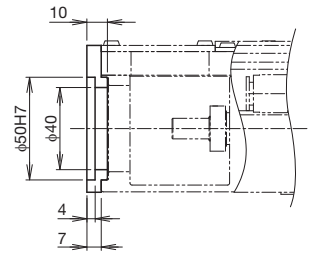
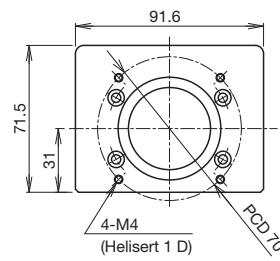

CSKR**	Actuator model
◇	◇: Intermediate flange

CSKR46
J

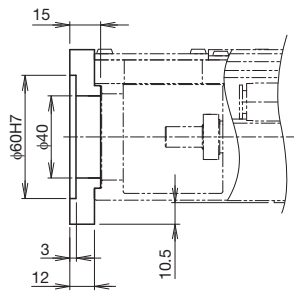
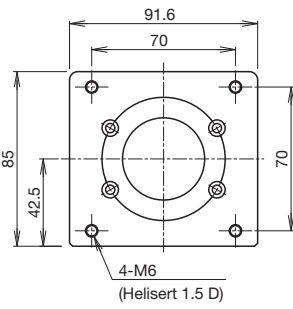

CSKR46
I

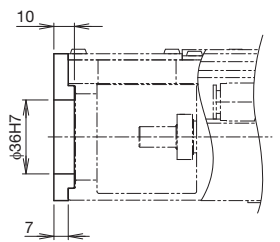
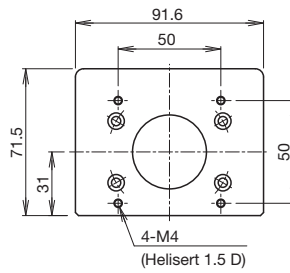

Load Rating and Radial Clearance

Model		CSKR20		CSKR26		CSKR33 ¹			CSKR46 ¹		
LM Guide	Basic dynamic load rating C (N)	6010		13000		17000			39500		
	Basic static load rating C ₀ (N)	8030		16500		20400			45900		
	Radial clearance (mm)	Normal grade/ High accuracy grade (H)	-0.004 to 0		-0.006 to 0		-0.004 to 0			-0.006 to 0	
Precision grade (P)		-0.006 to -0.004		-0.007 to -0.006		-0.012 to -0.004			-0.016 to -0.006		
Ball screw	Ball screw lead (mm)	1	6	2	6	6	10	20	10	20	
	Basic dynamic load rating Ca (N)	Normal grade/ High accuracy grade (H)	660	860	2350	1950	4400	2700	2620	4350	4240
		Precision grade (P)		1060		2390					
	Basic static load rating C _{0a} (N)	Normal grade/ High accuracy grade (H)	1170	1450	4020	3510	6290	3780	3770	6990	7040
Precision grade (P)			1600		3900						
Bearing (Fixed side)	Axial direction	Basic dynamic load rating Ca (N)	1150		2000		6250			6700	
		Static permissible load P _{0a} (N)	735		1230		2700			3330	

¹ Customized products can also be made to handle special environments or large axial loads (25% or more of the basic dynamic load rating Ca). Consult with THK.
Note 1) LM Guide load is the load rating per block.

Static Permissible Moment

Model	Static permissible moment		
	M _A	M _B	M _C
CSKR20-A	38	38	28
CSKR20-B	207	207	55
CSKR26-A	117	117	38
CSKR26-B	589	589	80
CSKR33-A	173	173	214
CSKR33-B	990	990	428
CSKR46-A	579	579	382
CSKR46-B	2852	2852	763

Note 2) "A" or "B" at the end of the model number indicates the slider type. A: Slider/B: Long slider
Note 3) Static permissible moment is the maximum permissible moment when the unit is stationary.

Accuracy Standards

Positioning repeatability

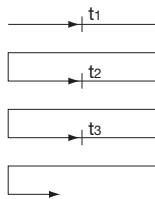

Positioning is repeated 7 times in the same direction at a given point, the stop position is measured, and half of the read maximum difference is obtained. This measurement is made at the center of the travel distance and at each of the two ends. The largest of the obtained values is set as the measurement value, and a ± sign is added to half of the maximum difference for display.

Running parallelism (vertical direction)

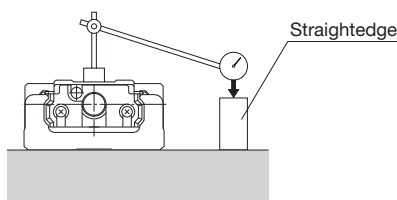

A straightedge is positioned on a surface plate with the CSKR mounted and the entire range of block movement is measured with a test indicator, taking the maximum difference in reading along the travel distance as the measured value.

Positioning accuracy

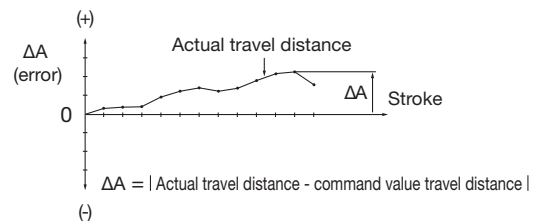

With the maximum stroke as reference length, the maximum error between the command value and the actual travel distance from the stroke start position is displayed as an absolute value.

Backlash

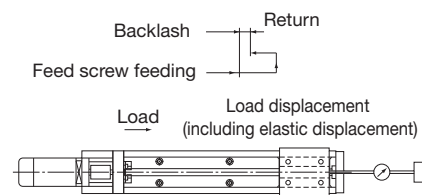

Using as a reference the test indicator reading with feeding applied to the block to move it slightly, a load is applied to the block from the same direction (table feed direction) in this state, without using the feed mechanism, and then the difference between the reference when opened and the return value is taken as the measured value. This measurement is made at the center of the travel distance and at each of the two ends; the largest of the obtained values is set as the measurement value.

Normal grade (no symbol)

Unit: mm

Model	Stroke ¹	Positioning repeatability	Positioning accuracy	Running parallelism (vertical direction)	Backlash	Starting torque (N·cm)
CSKR20	30	±0.01	Not specified	Not specified	0.02	0.8
	80					
	130					
CSKR26	60	±0.01				
	110					
	160					
CSKR33	210	±0.01				
	45					
	95					
	195					
	295					
CSKR46	395	±0.01			0.02	12.3
	495					
	595					
	190					
	290					
	390					
	490					
590						
690						
790						

High accuracy grade (H)

Unit: mm

Model	Stroke ¹	Positioning repeatability	Positioning accuracy	Running parallelism (vertical direction)	Backlash	Starting torque (N·cm)
CSKR20	30	±0.005	0.06	0.025	0.01	0.8
	80					
	130					
CSKR26	60	±0.005	0.06	0.025	0.01	2.3
	110					
	160					
CSKR33	210	±0.005	0.06	0.025	0.02	8.7
	45					
	95					
	195					
	295					
CSKR46	395	±0.005	0.1	0.035	0.02	12.3
	495		0.12	0.04		
	595		0.1	0.035		
	190					
	290					
	390		0.12	0.04		
	490					
590						
690	0.15	0.05				
790						

Precision grade (P)

Unit: mm

Model	Stroke ¹	Positioning repeatability	Positioning accuracy	Running parallelism (vertical direction)	Backlash	Starting torque (N·cm)
CSKR20	30	±0.003	0.02	0.01	0.003	1.9
	80					
	130					
CSKR26	60	±0.003	0.02	0.01	0.003	6.1
	110					
	160					
CSKR33	210	±0.003	0.02	0.01	0.003	18.3
	45					
	95					
	195					
	295					
CSKR46	395	±0.003	0.025	0.015	0.003	18.3
	495		0.03	0.02		
	595		0.025	0.015		
	190					
	290					
	390		0.03	0.02		
	490					
590						
690	0.03	0.02				
790						

¹ Stroke with slider (A type).

Precautions for Use

Application of These Products

- These products cannot be used for equipment or systems used in situations involving human life and limb.
- Be certain to contact THK in advance if considering utilizing for special applications, such as devices or systems used in passenger vehicles, medical equipment, aerospace, nuclear power, or electric power equipment.

Rotational motor drive products

Handling

- When using the product in locations exposed to constant vibrations or in special environments such as in clean rooms, vacuums, and low/high temperatures, contact THK.
- Tilting the table or the outer rail may cause them to fall due to their own weight.

Safety Precautions

- Before operation, thoroughly read and follow "Manipulating industrial robots - Safety" (JIS B 8433) and "Ordinance on Industrial Safety and Health" (Ministry of Health, Labour and Welfare of Japan).
- Be certain to read the instruction manual carefully, ensure you fully understand its contents, and observe precautions for safety.
- When installing, adjusting, inspecting, and maintaining the actuator body and related connected devices, be sure to unplug all plugs from outlets and lock them or prepare a safety plug so that the power cannot be turned on except by the operator. In a visible location, post a notice clearly stating that work is in progress.
- Never touch the operating parts of the actuator while it is live. Also, do not enter the operating range of the actuator while the product is in operation or a ready state.
- If multiple people are involved in the operation, confirm procedures such as work process, signs, and abnormalities in advance, and appoint a separate person for monitoring the operation.
- Do not disassemble these products unnecessarily. Doing so may lead to contamination by foreign materials or deterioration in accuracy.
- Take care not to drop or strike this product. Otherwise, it may cause injury or damage the unit. Even if there is no outward indication of damage, a sudden impact could prevent the unit from functioning properly.
- Do not exceed the permissible rotation speed when using the product. This could damage the product or otherwise cause it to malfunction. Please use the product within the range of speeds we have specified.
- Take care to avoid contamination of foreign material such as debris or cutting chips. This may result in damage to the ball circulation parts or decreased functionality.
- Contact THK regarding use in environments where coolant may enter the product.
- An impact-absorbing mechanism such as a shock absorber must be installed if there is a risk that the slider may collide with the stoppers attached to both ends of the movable range. The stoppers are not intended to absorb impacts during slider collision. Colliding with the stoppers during operation may result in damage or injury.
- Operation of the actuator over the torque limit value may lead to component damage or accidents.
- Keep the torque limit setting parameters within the allowable torque limit values.
- Motor wrap types do not include a safety device to protect users if the timing belt snaps. The customer must provide a safety device.
- Among these products are those with total body weight exceeding 20 kg. When transporting or assembling, always take safety into consideration to avoid injury or damage, and use appropriate conveying equipment.

Operating Environment

- When clean room Class 3 or Class 4 performance is required: ambient temperature between 16°C to 24°C, ambient humidity between 20% to 80% RH (no condensation).
- Places free from corrosive gas and flammable gas.
- Places where vibration or impacts are not transmitted to the unit.
- Places free from electrically conductive powder (such as iron powder), dust, oil mist, moisture, salt, and organic solvents.
- Places free from direct sunlight and radiant heat.
- Places free from strong electric and magnetic fields.
- Places that are easily accessible for maintenance and cleaning.
- When using the product in locations exposed to constant vibrations or in special environments such as in vacuums or low/high temperatures, contact THK.

Actuator Mounting Surface

- Mount to a flat surface suitable for mechanical machining or with comparable precision. Some products have regulated degrees of flatness.
- Mount to a base with sufficient rigidity.

Lubrication

- For effective use of the actuator's functions, lubrication is required. Insufficient lubrication may cause greater wear on moving parts, leading to premature damage.
- Do not use a mix of lubricants with different properties. Note that the encapsulated lubricant may differ depending on the product.
- Contact THK if using special lubricants.
- 100 km should be considered a guideline for greasing intervals. However, this may vary depending on the operating conditions, so THK recommends determining a greasing interval during the initial inspection.
- Regular lubricant may not be usable in special environments such as constantly vibrating locations, vacuums, or high/low temperatures. Contact THK in these cases.
- Contact THK if using oil lubrication.

Storage

- When storing this actuator, pack it as designated by THK and store it in a horizontal position away from high or low temperatures and high humidity.
- When storing the controller, avoid high or low temperatures and high humidity.

Disposal

- The product should be treated as industrial waste and disposed of appropriately.

Other Recommended Products

Clean Series LM Guide Actuator **CKSF**

- Ideal for transporting in clean environments due to the unique low dust-generating structure
- Achieves up to Class 4 cleanliness
- Supports long strokes up to 1500 mm

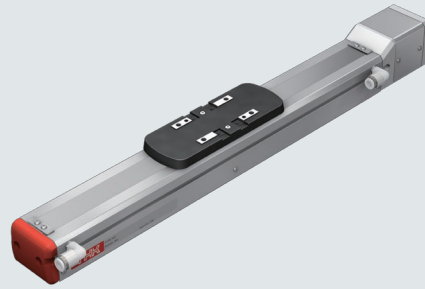

Clean Series Caged Ball LM Guide Actuator **CSKR**

- **LM Guide and Caged Ball**  are registered trademarks of **THK CO., LTD.**
- The actual products may differ from the illustrations and photographs in this catalog.
- Outward appearances and specifications are subject to change without notice for the purpose of improvement. Please consult with THK before using.
- Although great care has been taken in the production of this catalog, THK will not take any responsibility for damages resulting from typographical errors or omissions.
- For exports of our products and technologies and sales for export, our basic policy is to comply with the Foreign Exchange and Foreign Trade Act and other laws and regulations. Please consult us in advance if you want to export our products by the piece.

All rights reserved.

THK CO., LTD.

Headquarters 2-12-10 Shibaura, Minato-ku, Tokyo 108-8506 Japan

International Sales Department Phone: +81-3-5730-3860

www.thk.com
